



Manly  
Hydraulics  
Laboratory



Water  
Research  
Laboratory  
School of Civil and  
Environmental Engineering



Wamberal Terminal Coastal Protection Assessment

## DRAFT FINAL Stage 1 – Review of Previous Studies

May 2021

Prepared for:  
Central Coast Council



Central  
Coast  
Council

**Cover Photograph:** Beach erosion showing house wreckage, Wamberal, June 1978. Photograph by Gwen Dundon, Courtesy CCLS.

Published by NSW Department of Planning Industry Environment - Manly Hydraulics Laboratory (MHL) in association with UNSW Sydney - Water Research Laboratory (WRL) and Balmoral Group Australia (BGA).

Series Title: Wamberal Terminal Coastal Protection Assessment

Report Title: DRAFT FINAL Stage 1 – Review of Previous Studies

Report Numbers: MHL2778, WRL TR 2020/32

Contact:

**Edward Couriel**

Director, Manly Hydraulics Laboratory  
110b King Street, Manly Vale NSW 2093

T: 02 9949 0200

E: Edward.Couriel@mhl.nsw.gov.au

### Document Control

Issue/ Revision	Author	Reviewer	Approved for Issue	
			Name	Date
Draft01	J. Carley (WRL) C. Drummond (WRL) M. Phillips (MHL) S. Madani (BGA)	C. Drummond (WRL) R. Cox (WRL) E. Couriel (MHL) M. Phillips (MHL) S. Madani (BGA) G. Leslie (BGA)	E. Couriel (MHL)	16 Sep 2020
Draft02	M. Phillips (MHL)	E. Couriel (MHL) J. Carley (WRL)	E. Couriel (MHL)	19 Mar 2021
Draft Final	M. Phillips (MHL)	E. Couriel (MHL)	E. Couriel (MHL)	27 May 2021

### Report Classification

<input checked="" type="checkbox"/>	Public	Report existence and contents publicly available.
<input type="checkbox"/>	Release by consent only	Report existence and contents available only with consent of publisher
<input type="checkbox"/>	Private	Report existence and content are strictly confidential.

© Crown in right of NSW through the Department of Planning, Industry and Environment 2021

This publication is copyright and may incorporate moral rights of an individual. Other than for the purposes of and subject to the conditions prescribed under the Copyright Act, no part of it may, in any form or by any means, be reproduced, altered, manipulated, stored in a retrieval system or transmitted without prior written consent of the copyright owner or owner of moral rights. Any inquiries relating to consents and use of this publication, including by NSW Government agencies must be addressed to the Director, Manly Hydraulics Laboratory.

While this report has been formulated with all due care, the State of New South Wales does not warrant or represent that the report is free from errors or omissions, or that it is exhaustive. The State of NSW disclaims, to the extent permitted by law, all warranties, representations or endorsements, express or implied, with regard to the report including but not limited to, all implied warranties of merchantability, fitness for a particular purpose, or non-infringement. The State of NSW further does not warrant or accept any liability in relation to the quality or accuracy of the report and no responsibility is accepted by the State of NSW for the accuracy, currency, reliability and correctness of any information in the report provided by the client or third parties.

# Foreword

In 2020 NSW government’s professional specialist advisor, Manly Hydraulics Laboratory (MHL) in association with the Water Research Laboratory (WRL) of UNSW Sydney and Balmoral Group Australia (BGA) were commissioned by Central Coast Council to undertake the *Wamberal Terminal Coastal Protection Assessment*. The assessment outcomes are being delivered via a series of reports for the following stages of work:

1. **Review of previous studies (this report)**
2. Coastal protection amenity assessment
3. Seawall concept design options
4. Sand nourishment investigation
5. Provision of coastal monitoring (online webpage)
6. Cost benefit analysis and distributional analysis of options

This report provides the outcomes of Stage 1 of the Wamberal Terminal Coastal Protection Assessment, namely the review of previous studies relevant to coastal protection works at Wamberal Beach. The report contains a compiled review and summary of over 30 studies previous studies relevant to the context of the Wamberal Terminal Coastal Protection Assessment. Findings from the review have been used to guide and inform subsequent works and stages of the project.

This report is issued as Draft Final and will be finalised following public consultation along with a summary report that integrates key findings of all stages of the Wamberal Terminal Coastal Protection Assessment.

The report is classified as publicly available.

## Executive Summary

Wamberal Beach is within the traditional boundaries of Darkinjung (Darkinyung) land. Over the past 50 years development along the foredune of Wamberal Beach has had a history of damage and loss due to coastal erosion events. Managing risks to public safety and built assets, pressures on coastal ecosystems and community uses of the coastal zone make up the priority management issues of the certified Gosford Beaches Coastal Zone Management Plan (CZMP, 2017). Undertaking a review of terminal protection design for Wamberal Beach, coupled with the provision of beach nourishment (in accordance with Section 27 of the Coastal Management Act 2016), was a key recommended action of the CZMP (2017).

This report forms part of a broader series of work, the Wamberal Terminal Coastal Protection Assessment, recently undertaken to progress the key recommended management actions for Wamberal Beach from the Gosford Beaches Coastal Zone Management Plan (2017). The Wamberal Terminal Coastal Protection Assessment includes a *detailed review of previous studies (Stage 1 – current report)*, amenity assessment of coastal protection options (Stage 2), development of seawall concept design options (Stage 3 current report), sand nourishment investigation (Stage 4), implementation of coastal monitoring initiatives (Stage 5) as well as an updated cost-benefit analysis and distributional analysis of management options for Wamberal Beach (Stage 6). A summary report, integrating findings of all stages of the Wamberal Terminal Coastal Protection Assessment will be provided upon the finalising of all the aforementioned assessment reports.

This report provides the outcomes of Stage 1 of the Wamberal Terminal Coastal Protection Assessment, namely a compiled review and summary of over 30 studies previous studies relevant to the context of the Wamberal Terminal Coastal Protection Assessment. Findings from the review have been used to guide and inform subsequent works and stages of the project.

Extreme erosion during storms in 1974 (including the Sygna storm) resulted in emergency dumping of rock and sandbags by the Australian Army and the NSW SES. Two houses were lost due to storm erosion in 1978, with one of these lost houses resulting in the Egger legal case. Mrs Egger sued Gosford Shire Council and Mrs Brendel (the developer of 'Manyana' building) "for damages for negligence but ultimately the suit did not proceed against Mrs Brendel, as ... these parties had resolved the matter between themselves." The judgement stated that the apartment development known as Manyana was initially refused by Council in 1968 due to coastal hazards. A revised application set further back and founded on piles was approved. An ad hoc seawall fronting this development caused end effect erosion to its north. All four coastal expert witnesses agreed that a rip had formed in front of the Egger property, contributing to the erosion which led to its collapse. Smart, J, found that the seawall fronting Manyana contributed to the formation of this rip, but his judgment was "on the balance of probabilities. ... [the] balance was a fine one". He also found that no Council engineer or Council in 1968 would have been expected to have knowledge of such processes, so no adverse findings were made against Council. These findings were largely confirmed in an appeal hearing where the judgement of Smart was reviewed. It examined foreseeability, duty of care, liability, proximity and negligence. The Court of Appeal concurred that Council was not negligent. Mrs Egger was ordered to pay one half of the costs of the original hearing and the full costs of the appeal. That is, Council was ordered to pay half the costs of the original case because it (Council) lost on one issue - the issue of causation.

Following the erosion events of the 1970's a number of studies were undertaken investigating coastal processes, hazards and management of Wamberal Beach. The PWD (1985) study covered Avoca and Wamberal beaches and was the first modern coastal engineering study for this area. The PWD (1994) study estimated long term recession at Wamberal of 0.3 m/year and design storm erosion of 250 m<sup>3</sup>/m. Sand was believed to be lost to offshore reefs and canyons, and into the lagoons. The 1995 Coastal Management Study (CMS) and Coastal Zone Management Plan (CZMP, 1995) recommended either ongoing large-scale sand nourishment or a terminal protection in the form of a seawall.

In the late 1990's, a range of seawall options were canvassed by WRL (1998), with Council and its committee selecting a Seabee seawall with a wave return crest. The design of this was further developed and detailed by WRL. It was a whole of embayment design (lagoon to lagoon) and included detailed consideration of the alignment and physical modelling to refine crest elevations of 6 to 8 m AHD along the structure. The Seabee design was estimated to cost: \$7.2 million for 1360 m, \$5,300/m and \$90,000 per 17 m property frontage. In 2004, 120 m of the seawall design at the northern end was realigned due to development at 17 Calais Rd, Wamberal (MHL, 2004). As part of the study costs to construct the seawall were revised from \$7.2 million to \$8.2 million.

An Environmental Impact Statement (EIS) for this seawall was prepared by MHL (2003). The seawall was considered with accompanying periodic small-scale (estimated at 20,000 m<sup>3</sup>/year) beach nourishment to maintain beach amenity. The only potentially viable alternative was found to be large-scale sand nourishment (initial 900,000 m<sup>3</sup> and ongoing 200,000 m<sup>3</sup> every 10 years), but this was restricted by the lack of an accessible sand source.

Securing financial support has been an ongoing stumbling block for the construction of the seawall design. The Gosford Beaches Coastal Zone Management Plan (CZMP, 2017) reported: "On the 30 March 2006, the Mayor, the General Manager and Council's Principal Environmentalist met with the Minister Kelly along with his Policy Adviser on Emergency Services. At the meeting Council presented a detailed briefing paper. In summary, the briefing paper requested funding assistance of a one-off request of \$2.8 million from the State Government towards the construction of an \$8.2 million terminal protection structure (seawall) along Wamberal Beach. Council sought a similar financial assistance from the Federal Government of \$2.8 million and intended to seek the balance of \$2.8 million from the 78 residential properties that front Wamberal Beach to cover the total project cost of \$8.2 million. Council has since endeavoured to source grant funds through the State's Coastal Management Program and the Federal Government's Natural Disaster Mitigation Program. Council has also lobbied State and Federal governments, however, all efforts to secure financial assistance for the project have been unsuccessful."

More recently in the last 10 years, coastal hazard and management studies have been undertaken for Wamberal Beach. The Coastal Hazard Definition Study (CHDS, 2014) found the following for Wamberal Beach:

- Underlying recession of 0.2 m/year
- A Bruun Factor of about 43, that is, recession due to sea level rise (SLR) would be 43 times the SLR
- "Design" (nominally 100-year Annual Recurrence Interval 'ARI') storm erosion of 250 m<sup>3</sup>/m
- 68 dwellings potentially impacted by coastal hazards by 2050

The Gosford Beaches Coastal Management Study (2015) and Coastal Zone Management Plan (CZMP, 2017) concluded that the only viable options for Wamberal were terminal protection in the form of a seawall and sand nourishment to increase storm buffer, with large scale sand

nourishment constrained by the absence of an accessible sand source.

Earlier coastal hazard studies were undertaken to best practice of the time, and adopted “design”, “conservative”, “precautionary”, 100-year ARI/1% Annual Exceedance Probability (AEP) parameters. While these inputs remain relevant for planning purposes and engineering assessments, they may overstate the economic losses associated with coastal hazards. Therefore, OEH (2016) undertook probabilistic coastal hazard assessment for the years 2034 and 2064 to best contemporary practice, to provide quantitative input for a cost benefit analysis.

The Cost Benefit Analysis (Marsden Jacob Associates, 2017) assessed eight coastal management options relative to the status quo. It found that that 84 private properties with an average improved value of \$2.8 million and total value of \$235 million were potentially vulnerable to coastal hazards. Only Planned Retreat had a positive Net Present Value (NPV) and Benefit Cost Ratio (BCR) above 1, but the NPV for this (\$1.2 million) was still less than the value of a single house. Retreat was considered to be at the owners’ loss. For all protection options, the “avoided impacts on buildings and land” were about \$14 million. This can be compared with a total market value of potentially impacted property of \$235 million, noting that future losses are discounted. The \$221 million differential between these two values could comprise components of: future discounting, piled houses not being lost, only rare and future events impacting some properties, exclusion of the value of the 32% of properties estimated to be owned by non-residents (this was included in the sensitivity tests), and a transfer of value into the “increase in land values elsewhere within the LGA”.

Additional key economic studies have been reviewed and highlight the need for an updated cost benefit and distributional analysis of coastal management options for Wamberal Beach that is developed in close collaboration with coastal engineers and utilises up-to-date information and assumptions that are tested to best capture the losses and benefits of all interested parties. This is to be undertaken recognising that results of such analysis are only one tool used in the decision-making process for selecting a preferred option (i.e. it alone won’t tell you what the answer should be) and are to be considered alongside broader inputs such as coastal engineering and management studies, stakeholder consultation, and legislative requirements.

It has now been 46 years since the Australian Army and SES undertook emergency rock and sandbag protection for most of the houses at Wamberal, and 35 years since the first PWD study of the coastal hazards prevailing there. Underlying recession has continued at 0.2 m/year since then, together with SLR of 1 to 3 mm/year. Thus, the need for active coastal management is now greater than it was during the earlier storm events and studies. All previous coastal management studies have recommended terminal protection in the form of a seawall and sand nourishment as the most viable options for providing protection and maintaining foreshore amenity of Wamberal Beach. Large scale sand nourishment is constrained by the absence of an accessible sand source, this absence being legislative and planning rather than physical, and may result in further implications on flooding and entrance management.

Furthermore it is now over 20 years since the previous seawall designs were developed for Wamberal Beach, with the Gosford Beaches CZMP (2017) highlighting the need for an updated review of the previous design and updated investigation into potential sand sources for beach nourishment. Since the former seawall design new information and datasets have become available to inform the development of seawall design options, and the area has seen substantial changes in beachfront home ownership, property values and community values. Long-term shoreline datasets from satellite imagery and photogrammetry have now become available and

combined with new methodologies provide an opportunity to undertake a more detailed assessment of the potential impacts of seawall designs on beach width and amenity.

In July 2020 during the undertaking of this review, Wamberal Beach experienced substantial coastal erosion resulting in damages to beach front properties and more than 4000 tonnes of temporary emergency rock protection being placed on the beach. This recent event provides key learnings of the costs and impacts associated with the present status quo of emergency response and reactive ad-hoc protection works during major coastal erosion events, highlighting the importance of implementing a more sustainable long-term coastal management strategy. The event has also led to heightened community interest in coastal management options for Wamberal Beach with opportunity to re-engage with and understand stakeholder values.

An updated study of concept design options for terminal protection at Wamberal Beach is warranted, incorporating the following:

- Development and costings of seawall concept design options for Wamberal Beach using up to date information, methodologies and standards including sea level rise implications.
- Impact assessment of seawall design options on beach width and amenity using up to date information and methodologies.
- Updated sand nourishment investigation including sources, requirements and costings.
- Updated cost-benefit and distributional analysis of different seawall concept design options alongside other options including planned retreat and the present status quo (informed by recent events including impacts and emergency response costings).
- Community engagement to inform a preferred option and considerations for detailed design.

# Contents

1	Introduction .....	1
1.1	Background .....	1
1.2	Study location .....	2
1.3	Stage 1 objectives.....	4
1.4	Stage 1 overview .....	4
2	Brief reviews of selected studies .....	7
2.1	PWD (1985) Wamberal Beach and Avoca Beach: Coastal Engineering Advice .....	7
2.2	AWACS (1994) Entrance dynamics of Wamberal, Terrigal, Avoca & Cockrone Lagoons..	9
2.3	PWD (1994) Gosford Coastal Process Investigation .....	10
2.4	Webb, McKeown & Associates (1995) Wamberal Lagoon Estuary Processes .....	10
2.5	Coastal Zone Management Plan (CZMP, 1995).....	10
2.6	DCP No 89 (1996) .....	11
2.7	Hudson (1997) Gosford City Council Open Ocean Beaches Geotechnical Investigations	11
2.8	MHL (1998) Terrigal Lagoon dredging .....	11
3	Egger legal cases (1987) .....	12
3.1	Original Egger case .....	12
3.2	Egger Case appeal .....	16
4	WRL (1998) reports .....	17
4.1	WRL Technical Report 97/22 Design study.....	17
4.2	WRL Technical Report 97/26 Physical modelling study .....	29
4.3	WRL Technical Report 98/05 Wamberal Beach terminal protective structure - Technical specification .....	32
5	MHL (2003) Seawall Environmental Impact Statement .....	33
6	MHL (2004) Realignment and Cost Review .....	34
7	WorleyParsons (2014) Coastal hazard definition study .....	37
7.1	WorleyParsons (2014) body.....	37
7.2	WorleyParsons (2014) Appendix H .....	42
8	WorleyParsons (2015) Coastal management study .....	46
8.1	Summary of previous studies.....	46
8.2	Assumptions for Costing of Options .....	48
8.3	Net present value costings.....	49
8.4	Attempt at securing a funding agreement.....	50
8.5	Emergency action plan .....	50
8.6	Major options considered for Wamberal.....	51
8.7	Consultation.....	51



8.8	Excluded options .....	52
8.9	Beach usage statistics .....	52
9	CZMP (2017) Gosford Beaches Coastal Zone Management Plan .....	53
9.1	Major action items for Wamberal.....	53
9.2	Consultation.....	53
9.3	Hazard lines.....	53
10	OEH (2016) Probabilistic shoreline modelling.....	57
11	Marsden Jacob Associates (2017) Cost Benefit Analysis .....	60
11.1	Summary .....	60
11.2	Outcomes .....	60
12	Brief review of selected conference and journal papers.....	64
12.1	Blumberg and Watson (2007) Basement structures .....	64
12.2	Lord and Macdonald (2016) Managing Wamberal Beach – The Forgotten Twin .....	64
12.3	Horton and Rajaratnam (2019) Cost Benefit Analysis in Coastal Management – Getting it Right and Getting it Wrong .....	65
13	Review of additional economic studies .....	66
13.1	Preamble .....	66
13.2	Fei Yang (2014). Employ Cost-Benefit Analysis to Evaluate the Cost Efficiency of Major Sea Level Rise Adaptation Strategies .....	66
13.3	Balmoral Group Australia (2014). Cost-Benefit Analysis of Options to Protect Old Bar from Coastal Erosion.....	66
13.4	Balmoral Group Australia (2015). Cost-Benefit Analysis of Coastal Management Options for Lake Cathie.....	67
13.5	Sean Pascoe and Amar Doshi (2018). Estimating coastal values using multi-criteria and valuation methods, CSIRO. ....	68
13.6	City of Newcastle (2020). Cost-benefit analysis for Stockton Beach coastal management program.....	68
13.7	Further resources .....	69
13.8	Media and websites .....	69
14	Conclusions.....	71
	References .....	74

## List of Tables

Table 1.1 List of reference material .....	5
Table 9.1 Beach usage statistics.....	52
Table 12.1 Summary of results of the Cost-Benefit Analysis .....	61
Table 12.2 CBA Statistics of interest.....	61

## List of Figures

Figure 1.1: Location of study site showing elevation contours and mean nearshore wave climate. .	3
Figure 2.1 Seabed mapping (PWD, 1984).....	8
Figure 3.1 Zoomed aerial view of subject properties (Horton, 2016).....	14
Figure 3.2 Collapse of house at 23b Ocean View Drive Wamberal in June 1978 (News Limited)..	15
Figure 3.3 Collapse of house at 23a Ocean View Drive Wamberal in June 1978 .....	15
Figure 4.1 Nearshore waves and water levels for -2 m AHD scour level (WRL Figure 15) .....	19
Figure 4.2 Basalt option .....	20
Figure 4.3 Basalt cross section .....	21
Figure 4.4 Sandstone cross section .....	22
Figure 4.5 Concrete pile option .....	23
Figure 4.6 Concrete pile cross section .....	24
Figure 4.7 Seabee option.....	25
Figure 4.8 Seabee cross section.....	26
Figure 4.9 Seabee with piled toe cross section .....	27
Figure 4.10 Adopted alignment .....	28
Figure 4.11 Oblique view of Seabees in flume .....	29
Figure 4.12 Overhead view of Seabees in flume .....	30
Figure 4.13 Side view of wave runup .....	30
Figure 4.14 Overhead view of wave runup.....	31
Figure 4.15 Seabee configuration .....	31
Figure 4.16 Wave deflector geometry .....	32
Figure 6.1: Recommended Terminal Protection Structure crest and rear alignment from MHL (2004) .....	35
Figure 6.2: Recommended Terminal Protection Structure crest and toe realignment from MHL (2004) .....	36
Figure 8.1 Dune stability cross section (WP Figure 46).....	38
Figure 8.2 Present day coastal hazard lines – south (WP, 2015 Figure 21) .....	39
Figure 8.3 Present day coastal hazard lines - north (WP, 2015 Figure 21).....	40
Figure 8.4 Lots potentially affected by coastal hazards (WP, 2015 Figure A3.7) .....	41
Figure 8.5 Photogrammetry blocks 1 to 5 (WP Figure H1) .....	43
Figure 8.6 Photogrammetry blocks 5A to 8 (WP Figure H2).....	44

Figure 8.7 Alongshore volume change (WP Figure H8) ..... 45

Figure 9.1 Extent of rock protection works placed in 1974 (WP, 2015, Figure 39)..... 47

Figure 10.1 2050 and 2100 coastal hazard lines (WP, 2017, page 431) ..... 54

Figure 10.2 Stormwater infrastructure (WP, 2017, Figure 8) ..... 55

Figure 10.3 Sewer and water infrastructure (WP, 2017, Figure 9)..... 56

Figure 11.1 Potential shoreline change at 2034 (OEH, 2016, Figure 3)..... 58

Figure 11.2 Potential shoreline change at 2064 (OEH, 2016, Figure 4)..... 59

Draft

# 1 Introduction

## 1.1 Background

Wamberal Beach is within the traditional boundaries of Darkinjung (Darkinyung) land, which extends from the Hawkesbury River in the south, Lake Macquarie in the north, the McDonald River and Wollombi up to Mt Yengo in the west and the Pacific Ocean in the east.

Wamberal Beach is a sandy ocean coast shoreline, situated within the Wamberal-Terrigal embayment on the NSW Central Coast shown in Figure 1.1. Over the past 50 years development along the foredune of Wamberal Beach has had a history of damage and loss due to coastal erosion events. Managing risks to public safety and built assets, pressures on coastal ecosystems and community uses of the coastal zone make up the priority management issues of the certified Gosford Beaches Coastal Zone Management Plan (CZMP, 2017) with the primary objective

*“to protect and preserve the beach environments, beach amenity, public access and social fabric of the Open Coast and Broken Bay beaches while managing coastal hazard risks to people and the environment”.*

Major actions recommended for Wamberal Beach from the CZMP (2017) were the following:

- *“TW11 Terminal protection - Council to action review, design and funding of terminal protection structure for Wamberal.”*
- *“TW14 Investigate sources of sand and feasibility of beach nourishment for Wamberal Beach.”*
- *“TW15 Beach nourishment coupled with a terminal revetment to increase buffer against storm erosion.”*

In 2020 NSW government’s professional specialist advisor, Manly Hydraulics Laboratory (MHL) in association with the Water Research Laboratory (WRL) of UNSW Sydney and Balmoral Group Australia (BGA) were commissioned by Central Coast Council to undertake the *Wamberal Terminal Coastal Protection Assessment*. A key outcome of the study is a series of reports for the following stages of work:

- 1. Review of previous studies (current report)**
2. Coastal protection assessment
3. Seawall concept design options
4. Sand nourishment investigation
5. Provision of coastal monitoring
6. Cost benefit analysis and distributional analysis of options

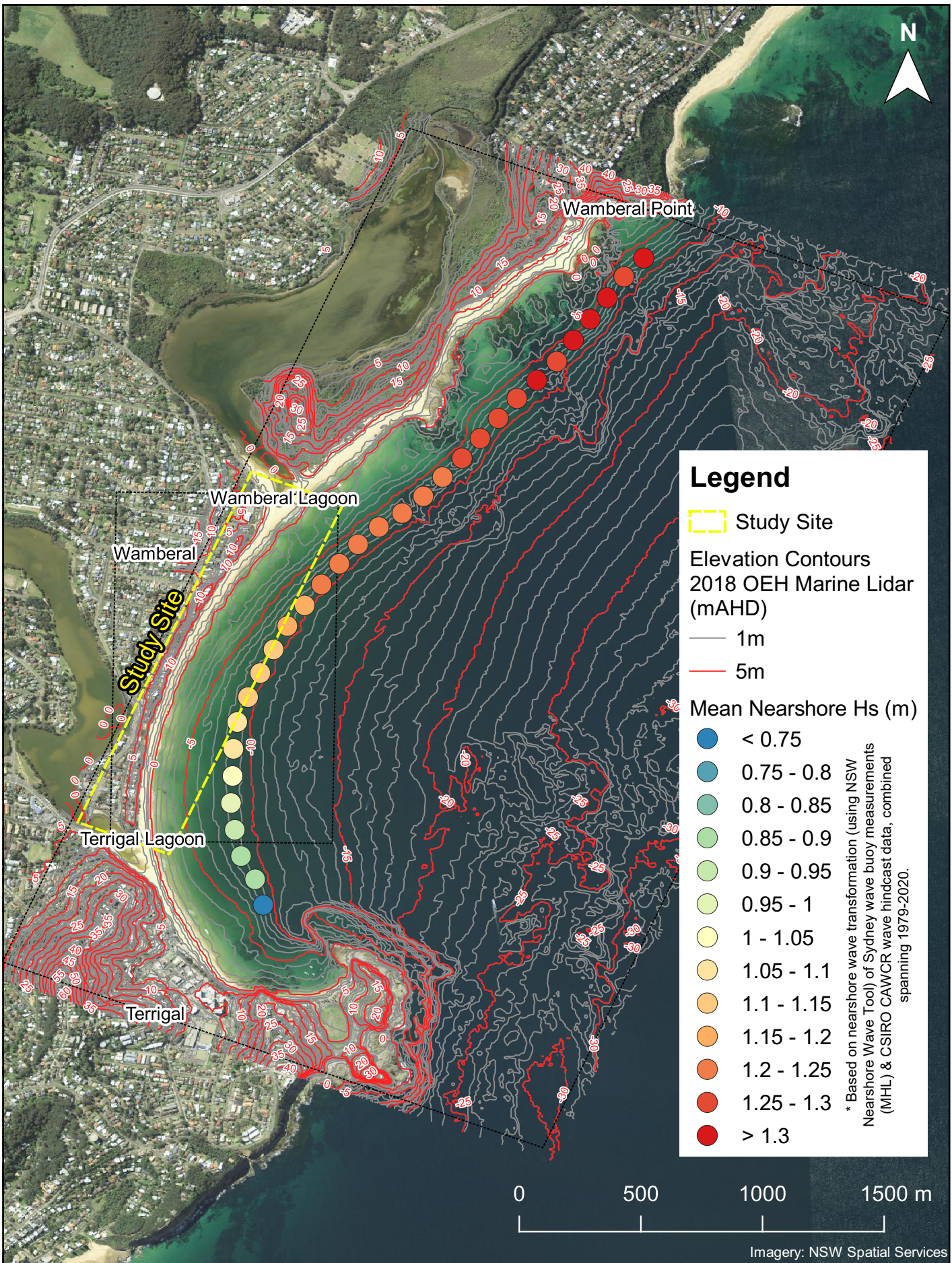
This report provides the outcomes of Stage 1 of the Wamberal Terminal Coastal Protection Assessment, namely a literature review of previous work related to the study. The report contains a compiled review and summary of over 30 studies previous studies relevant to the context of the Wamberal Terminal Coastal Protection Assessment. Findings from the review have been used to guide and inform subsequent works and stages of the project.

## 1.2 Study location

Wamberal beach is situated in the sandy Terrigal-Wamberal embayment on the New South Wales (NSW) Central Coast as shown in Figure 1.1. The sandy embayment is classified as stationary-receded coastal barrier system containing two coastal lagoon (Wamberal and Terrigal Lagoon) entrances that intermittently close to the ocean due to the infilling of marine sand (Hudson, 1997). The embayment is composed of fine to medium grained quartz sand and bounded by offshore rocky reefs (20-25m water depth) and sandstone/shale headlands at Terrigal in the south and Wamberal Point in the north.

Tides in the region are microtidal with mean spring and neap ranges of 1.3 m and 0.8 m respectively (Couriel et al., 2012). The regional wave climate is of moderate to high energy. Deepwater wave data collection has been undertaken off the coastline near Sydney from 1987 initially with non-directional measurements and since 1992 with directional measurements. Waves are predominantly from the SSE direction with an average significant wave height ( $H_s$ ) of 1.6 m and peak wave period ( $T_p$ ) of 10 s. Deepwater  $H_s$  exceeds 3 m for approximately 5% of the time and has been observed to reach up to 9 m during high energy events, most commonly driven by intense extratropical cyclones known as East Coast Lows (ECLs) that track near the coast in the Tasman Sea (Harley et al., 2017).

The present study focuses 1.5km stretch of beach situated between Terrigal and Wamberal Lagoon entrances (termed Wamberal Beach) as shown in Figure 1.1. Nearshore wave conditions at the 10m contour of the study site were estimated from historical measurements and hindcasts using the [NSW Nearshore Wave Tool](#) (Baird Australia and MHL, 2017). Average nearshore (10m depth contour) significant wave height ( $H_s$ ) in the study site range from 0.93 m in the south at Terrigal Lagoon to 1.21 m in the north at Wamberal Lagoon, with the southern end partially sheltered from predominant SSE wave energy.



**Legend**

- Study Site
- Elevation Contours  
2018 OEH Marine Lidar (mAHD)
- 1m
- 5m
- Mean Nearshore Hs (m)
- <math>< 0.75</math>
- 0.75 - 0.8
- 0.8 - 0.85
- 0.85 - 0.9
- 0.9 - 0.95
- 0.95 - 1
- 1 - 1.05
- 1.05 - 1.1
- 1.1 - 1.15
- 1.15 - 1.2
- 1.2 - 1.25
- 1.25 - 1.3
- > 1.3

\* Based on nearshore wave transformation (using NSW Nearshore Wave Tool) of Sydney wave buoy measurements (MHL) & CSIRO CAWCR wave hindcast data, combined spanning 1979-2020.

0 500 1000 1500 m

Imagery: NSW Spatial Services



LOCATION OF STUDY SITE SHOWING ELEVATION CONTOURS (2018 OEH MARINE LIDAR) AND AVERAGE NEARSHORE WAVE CLIMATE (-10M CONTOUR)

**Manly Hydraulic Laboratory**

Report MHL2778  
Figure 1.1

Figure1.1.pdf

### 1.3 Stage 1 objectives

The Stage 1 report aims to compile and review previous studies related to coastal hazards, coastal management and previous design of terminal protection for Wamberal Beach. The report provides summary of key references and findings that have been used to guide and inform subsequent works and stages of the project.

### 1.4 Stage 1 overview

Wamberal Beach has had a long history of beachfront development and coastal erosion. This document summarises and reviews literature relevant to coastal management and a proposed seawall for Wamberal. This literature is presented in approximate chronological order.

Documents reviewed in the body of this report are listed in Table 1.1. It excludes sand nourishment studies, geotechnical studies and individual Development Applications. Review of available geotechnical data and sand nourishment studies have been undertaken separately as part of Stage 2 and Stage 4 works respectively. A preliminary review of economic studies is included with ongoing research to be presented as part of the Stage 6 Cost Benefit Analysis.

Several older documents are referenced within the more recent documents reviewed in this report and have not been included in the present review. These may have been superseded or built upon in the more recent studies. These include a Strategy Policy Paper was developed (Gosford Council, 2004) specifically to consider a protection strategy for Wamberal Beach, which recommended that the Wamberal Terminal Protection Structure be endorsed as the preferred protective strategy for Wamberal Beach.

Table 1.1 List of reference material

Designation	Title	Length	Detailed summary	Minor summary
PWD (1984)	Seabed maps, Gosford	1		✓
PWD (1985)	Gosford Coastal Processes Investigation			✓
Smart J, (1987)	Egger Case in the Supreme Court of New South Wales Common Law Division No 14992 of 1979, Egger v Gosford Shire Council and Anor – Judgement 10 July 1987	85	✓	
Hope (1), Samuels And Clarke (2) JJA	Supreme Court Of New South Wales Court Of Appeal, Hope (1), Samuels And Clarke (2) JJA, 588 Of 1987, 22, 23, 24, 27 June 1988, 10 March 1989	40		✓
AWACS (1994)	The entrance dynamics of Wamberal, Terrigal, Avoca and Cockrone Lagoons			✓
PWD (1994)	Gosford Coastal Process Investigation			✓
Webb McKeown (1995)	Wamberal Lagoon Estuary Processes			✓
Gosford City Council (1995)	Coastal Management Study and Coastal Management Plan Gosford City Open Beaches, WBM Oceanics Australia, Planning Workshop			✓
Gosford City Council (1996)	DCP No 89 (1996)			✓
WRL (1997)	Wamberal Beach Terminal Protection Structure – Physical Modelling Study, WRL Technical Report 97/26	42	✓	
Hudson, J P (1997)	Gosford City Council Open Ocean Beaches Geotechnical Investigations (Avoca Beach, Wamberal Beach, Forresters Beach)		✓	
MHL (1998)	MHL (1998) Terrigal Lagoon dredging			✓
WRL (1998a)	Design study for Wamberal Beach: terminal protective structure	110	✓	
WRL (1998b)	Wamberal Beach Terminal Protection Structure – Final Design Drawings and Technical Specification, WRL Technical Report 98/05		✓	
MHL (2003)	Wamberal Beach and property protection: Environmental Impact Statement (2003), MHL Report MHL935, DPWS Report 98047, ISBN 0 7313 0716 X	145	✓	
MHL (2004)	Coastal Engineering Advice Realignment and Cost Review of Wamberal Terminal Protection Structure and Beach Nourishment. Letter Report CME6-00156.	27	✓	
Blumberg and Watson (2007)	Wamberal Beach basement structures: Provisional model for assessment of additional coastal hazards	7	✓	
BMT (2012)	WBM Coastal Zone Management Study for Gosford Lagoons R.N1997.001.01_Draft October 2012 (135 pages)	135		✓



Designation	Title	Length	Detailed summary	Minor summary
WorleyParsons (2014)	Gosford City Council open coast and Broken Bay beaches Coastal processes and hazard definition study	136 plus appendices	✓	
WorleyParsons (2014)	– Analysis of photogrammetric data – Terrigal-Wamberal Appendix H	25	✓	
WorleyParsons (2015)	Open Coast and Broken Bay Beaches Coastal Zone Management Study 301015-03417 – CS-REP-0001 16 Apr 2015	380 plus appendices	✓	
Horton Coastal Engineering (19 September 2016)	Coastal Engineering Report and Statement of Environmental Effects for Construction of Rock Revetment at 29, 31 and 33 Pacific Street and 23a, 23b and 25c Ocean View Drive Wamberal			✓
Lord and Macdonald (2016)	Managing Wamberal Beach – The Forgotten Twin	13		✓
WorleyParsons (2017)	Gosford Beaches Coastal Zone Management Plan 301015-03417 – 003 3 April 2017	492	✓	
OEH (2016)	Draft Forecast of Potential Shoreline Change Wamberal Beach (Gosford City Council) April 2016.		✓	
Marsden Jacob Associates (2017)	Wamberal Beach Management Options: Cost Benefit and Distributional Analysis		✓	
Horton and Rajaratnam (2019)	Cost Benefit Analysis in Coastal Management – Getting it Right and Getting it Wrong	8		✓
<b>Review of additional economic studies:</b>				
Fei Yang (2014)	Employ Cost-Benefit Analysis to Evaluate the Cost Efficiency of Major Sea Level Rise Adaptation Strategies			✓
Balmoral Group Australia (2014)	Cost-Benefit Analysis of Options to Protect Old Bar from Coastal Erosion			✓
Balmoral Group Australia (2015)	Cost-Benefit Analysis of Coastal Management Options for Lake Cathie			✓
Sean Pascoe and Amar Doshi, (2018)	Estimating coastal values using multi-criteria and valuation methods, CSIRO.			✓
City of Newcastle (2020)	Cost-benefit analysis for Stockton Beach coastal management program.			✓

## 2 Brief reviews of selected studies

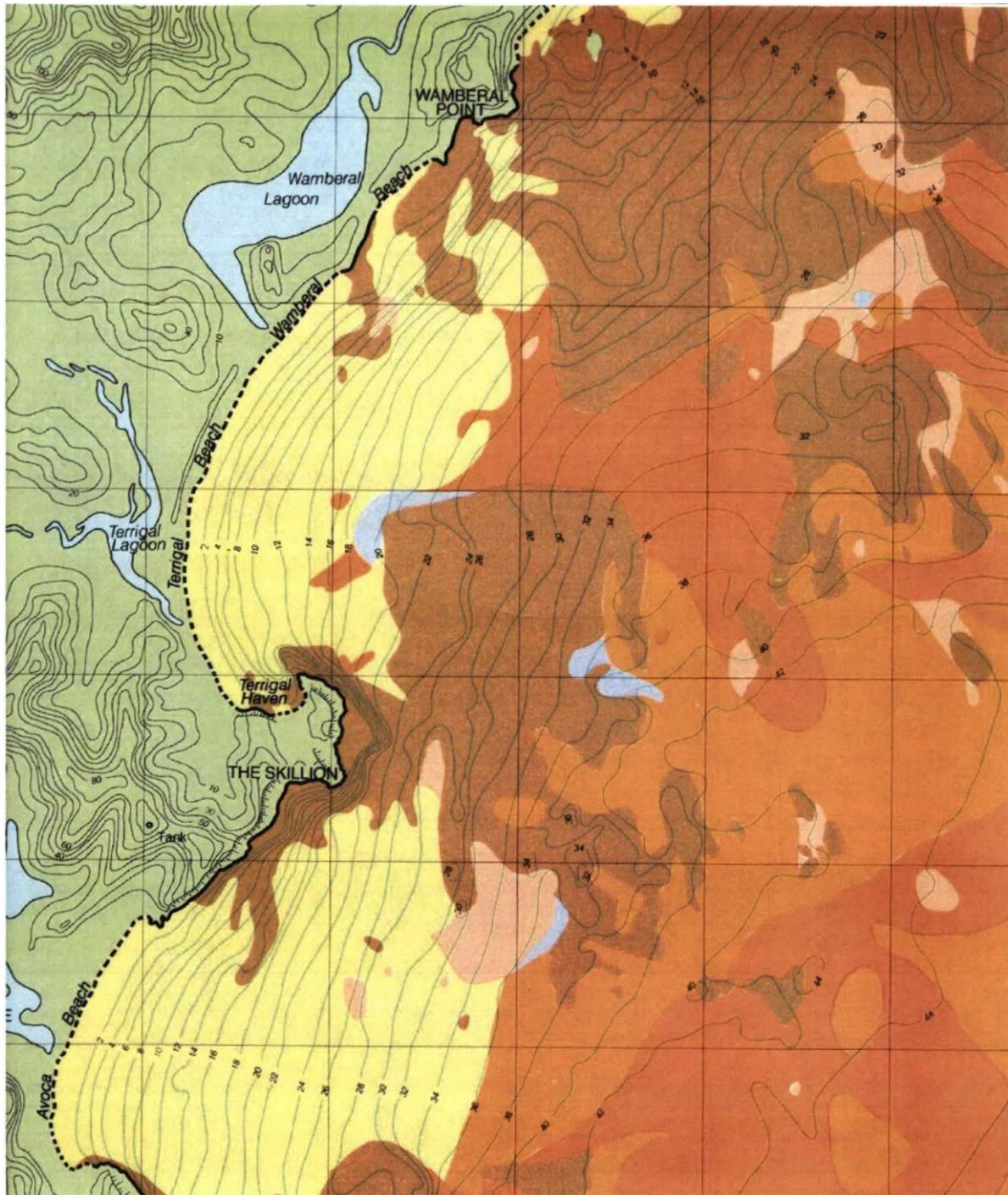
The reviews below are brief, with some based on *Wamberal Beach and property protection: Environmental Impact Statement* (MHL, 2003).

### 2.1 PWD (1985) Wamberal Beach and Avoca Beach: Coastal Engineering Advice

PWD (1985), Wamberal Beach and Avoca Beach: Coastal Engineering Advice, NSW Public Works Department Coastal Engineering Division, Report No PWD 85040, May.

This report represents the beginning of coastal hazard management research for the Gosford coastline. It documents the advice on coastal engineering matters provided by the NSW Public Works Department (PWD) to Gosford City Council. The report outlines the coastal processes operating along this section of coastline and describes the nature and extent of the coastal hazards. The available management options for mitigation of these hazards are assessed. This work was undertaken before the present day understanding of sea level rise.

In 1984 the PWD undertook detailed seabed mapping out to water depths of 50 m. The offshore area is characterised by bedrock reef, dykes, gravel patches and coarse sand (Figure 2.1). The headland reefs at Wamberal coalesce with the surrounding seabed at water depths of approximately 25 m, in contrast to 40 m off nearby headlands. This shallow reef has important implications for the sediment transport processes in the region. Sand transported offshore during storm events can become trapped in the shallow reef and be prevented from returning to the beach system.



Map courtesy of NSW Public Works Department (Survey 1984-1989)

All Levels to Australian Height Datum (AHD)

**LEGEND**

- |   |   |
|---|---|
|  Medium to coarse grained, orange coloured sand with typically 40% shell |  Rock reef   |
|  Very coarse grained orange coloured gravelly sand                       |  Reef materials consisting of shell, reef and coral fragments and small amounts of sand and gravel |
|  Fine to medium grained, golden coloured sand with varying shell content |  Rock shoreline  |
|  Areas of reef partly covered by sand                                    |  Sandy shoreline   |

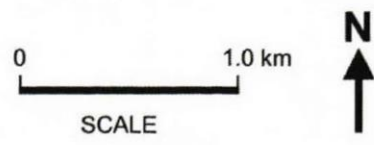


Figure 2.1 Seabed mapping (PWD, 1984)

## 2.2 AWACS (1994) Entrance dynamics of Wamberal, Terrigal, Avoca & Cockrone Lagoons

AWACS (1994), The entrance dynamics of Wamberal, Terrigal, Avoca and Cockrone Lagoons, Australian Water and Coastal Studies Report 93/24, by C Ribbons, D K Haradasa, A D Gordon, D A Luketina and R J Cox.

Key findings of this report include:

- The four Central Coast Lagoons of Wamberal, Terrigal, Avoca and Cockrone are subject to flooding from both local rainfall runoff and ocean waves. A major factor in both these flooding conditions is the beach berm geometry at the lagoon entrance.
- During rainfall runoff flooding when the lagoon is closed, the beach berm level has control over the flood levels in the lagoon. When the entrance channel breaks out to the ocean, the rate of discharge through the outlet channel will affect flood levels in the lagoon.
- During major ocean storms, the level and condition of the beach berm is critical in controlling the amount of waves overtopping the beach berm or waves entering the lagoon through an open entrance channel.
- Site specific conditions at each lagoon will influence flood inundation levels from either rainfall runoff or ocean flooding. These were estimated in the report.
- Lagoon breakout discharge curves were presented based on detailed observations at Dee Why and Narrabeen lagoon entrances.
- Observations and local knowledge indicate that ocean wave activity at the entrance of each lagoon has the potential to cause inundation in the vicinity of the lagoon entrances. An understanding of the local processes, combined with previous studies and research has suggested that inundation levels around 3.5m AHD to 4.0m AHD from ocean wave activity are possible along the lagoon foreshore near the entrance.

The following inundation data has been collected by Council:

*Wamberal Lagoon:*

- a) *A flood level for Wamberal Lagoon of 3.1m AHD was derived after examination of the 1974 flood event and discussions with residents*
- b) *Photographs taken on 2 June 1978 indicate debris marks on Remembrance Drive*
- c) *Council has surveyed this level from interpretation of the photograph and present topography at 2.53m AHD.*

*Terrigal Lagoon:*

- a) *The Clan Motel is suspected of being flooded during the May 1974 event. The floor level of the Motel is 2.5 m AHD and therefore the inundation level would have at least reached this level.*
- b) *Photographs of the 2 June 1978 event show debris marks on the lawn in front of the Clan Motel and wave action around the Motel. On the basis of present topography and these photographs, Council has surveyed the flood levels between 2.1 m AHD and 2.3 m AHD.*
- c) *Photographs of the 8 August 1986 event show debris marks and wave action around the Clan Motel. Council has surveyed these flood marks at around 2.2 m AHD and 2.3 m AHD.*
- d) *On 8 August 1986, the Council photographs show waves between 0.3 m to 0.5 m inside Terrigal Lagoon close to the beach. The Lagoon Book [a record book kept by Council] indicates that during this event the lagoon entrances may have been either partially open or more likely closed.*

## 2.3 PWD (1994) Gosford Coastal Process Investigation

NSW Public Works Department, 1994, Gosford Coastal Process Investigation, September 1994.

This study investigates the extent of coastal hazards and general coastal processes operating between MacMasters Beach and Forresters Beach on the NSW central coast. The report presents design values for assessment of management options such as ocean inundation and wave runup levels and storm erosion demand. Longer-term trends for beach recession and accretion are also identified.

Issues discussed include areas of potential slope failure and sea level rise implications. A projected scarp location, for the next 50 years, is presented for each beach, including the Terrigal/Wamberal Beach study area. This report was prepared in accordance with the coastline management process and provides the basis for assessment of management options.

Utilising photogrammetry from 1941 to 1993 (12 dates), the study estimated the following coastal hazard components:

- “Design” (nominally 100 year ARI) storm erosion: 250 m<sup>3</sup>/m
- Underlying recession of 0.3 m/year

## 2.4 Webb, McKeown & Associates (1995) Wamberal Lagoon Estuary Processes

Webb, McKeown & Associates (1995), Part W: Wamberal Lagoon Estuary Processes Study, Sydney.

This report contains information on the processes taking place within the Wamberal Lagoon to the north of the current study area. Discussion of processes is limited to tidal action and entrance behaviour. In relation to the proposed development, there are discussions on the Wamberal Lagoon Nature Area.

## 2.5 Coastal Zone Management Plan (CZMP, 1995)

Gosford City Council (1995), Coastal Management Study and Coastal Management Plan Gosford City Open Beaches, WBM Oceanics Australia, Planning Workshop.

The Management Study and Management Plan are contained within one cover and were produced in accordance with the procedures outlined in the NSW Government Coastline Management Manual (1990). The preparation of the Management Study included an extensive public consultation process. It describes the existing environment, land tenure, planning controls and recreational uses. The costs and social issues associated with a broad array of management options in relation to the study area are considered within the management study. The advantages and disadvantages for each of these options are assessed.

The Management Plan presents those management options considered to be viable as a result of the Management Study. In the case of Wamberal Beach the recommendations of the management plan were either for ongoing foreshore nourishment or terminal protection in the form of a seawall.

## 2.6 DCP No 89 (1996)

Gosford City Council (1996), Development Control Plan No. 89: Scenic Quality, GCC.

This is a Development Control Plan provided for under Section 72 of the Environmental Planning and Assessment Act 1979. The primary objective of the plan is to develop appropriate guidelines for the management of the landscape character for all land within the City of Gosford. The document divides all land within the City of Gosford into geographic units.

The coastline of Wamberal and Terrigal is described as an area of low absorption capacity, with concern of the visual prominence of development. Where a development application or a rezoning application is lodged Council must take the provisions of this plan into consideration.

## 2.7 Hudson (1997) Gosford City Council Open Ocean Beaches Geotechnical Investigations

Hudson, J. P., 1997, Gosford City Council Open Ocean Beaches Geotechnical Investigations (Avoca Beach, Wamberal Beach, Forresters Beach), Results of Conductivity and Drilling Investigations, Coastal and Marine Geosciences, for Gosford City Council.

One recommendation of the Gosford City Council Coastal Management Plan (CZMP, 1995) was for geotechnical investigations to identify any physical constraints such as bedrock which may influence predicted dune recession. This report is the outcome of that recommendation. The investigations were completed between June and August 1996.

The methods of investigation included conductivity measurements, drilling and laboratory field sample testing. The results for Wamberal included the verification of a bedrock interfluvium separating Terrigal and Wamberal lagoons which approaches the coast and high conductivity in areas with documented exposure of bedrock. The drilling results also supported the conductivity measurements. The investigations did not reveal the existence of any bedrock which would significantly alter predicted recession rates along Terrigal/Wamberal Beach. A localised area of elevated claystone bedrock which may affect any foundations for a terminal protection structure was mapped.

A more detailed review of Hudson (1997) and other geotechnical investigations of Wamberal Beach are provided in the Stage 2 Report: Coastal Protection Assessment (in draft).

## 2.8 MHL (1998) Terrigal Lagoon dredging

Manly Hydraulics Laboratory, 1998, Terrigal Lagoon Dredging - Feasibility Study, MHL report 902.

This report assesses the feasibility of deepening sections of the Terrigal Lagoon to improve aesthetics and ecology when the water level is low. The report details the history of dredging works and investigates water quality, flora and fauna ecology and sand and mud zones. The advantages and disadvantages of different management practices in relation to dredging options are assessed.

## 3 Egger legal cases (1987)

### 3.1 Original Egger case

Egger Case (Smart J, 1987) in the Supreme Court of New South Wales Common Law Division No 14992 of 1979, Egger v Gosford Shire Council and Anor – Judgement 10 July 1987 (85 pages).

The summary below attempts to summarise an 85-page judgement into two pages. Titles given to the experts below were as they were at the time of the hearing.

The so called Egger Case (Egger v Gosford Shire Council & Anor) was heard before the Supreme Court of New South Wales Common Law Division, No 14992 of 1979. The Judgement by Justice Smart dated 10 July 1987 (8 years after commencement) comprises 85 pages. The key coastal management and coastal policy aspects of the judgement are documented below.

Mrs Egger was the owner of 23a Ocean View Drive, Wamberal. Mrs Veronica May Brendel was the owner and developer of lots 7 and 8 Pacific Street [now also known as 25 Pacific Street], where a six-unit block was approved by Council in May 1968 and constructed during about 1968-1969. It became known as “Manyana” (Figure 3.1).

*“On the night of 20 June 1978 the sea eroded the sand dune in front of Mrs Egger’s home ... precipitating the collapse of much of her home onto the beach and into the sea.”* (Figure 3.2, Figure 3.3)

The initial development application for the Manyana development was submitted to Council in March 1968 and was rejected by Council, due in part to its location on a sand dune and proximity to the beach. In April 1968 an amended development application was submitted, which involved less excavation and a more landward location. The amended application was supported by a report from a consulting engineer Mr M G Madin, which according to Council *“... requires the building to be supported on reinforced concrete piles driven into a hard strata.”*

Mrs Egger sued Gosford Shire Council and Mrs Brendel *“for damages for negligence but ultimately the suit did not proceed against Mrs Brendel, as ... these parties had resolved the matter between themselves.”*

*“In 1974, in a period of severe storms and high seas .... Manyana was in danger of being undermined by the sea, and emergency work was carried out on the beach seaward or east of Manyana. These emergency works consisted of a line of concrete septic tanks (stated to be filled with either concrete or sand/gravel) embedded in the sand and backed and flanked by “considerable quantities of large rocks.”*

Mrs Egger claimed that the loss of her house was *“... as a result of the construction of the Manyana units and work carried out on and near the unit site and approved by Council, ...”* The particulars of Council’s “approval” were that Council actually “approved” the emergency works, *“..., or alternatively that the Council acquiesced in this work and allowed it to remain.”* It was not disputed that representatives of the body corporate and unit owners of Manyana met with members and officers of the Council, including the Shire President in response to the 1974 storm erosion event. *“Representatives of the Council saw the work being done and at least acquiesced in its execution.”*

Page 58: Various experts agreed that the Manyana seawall locked up 500 to 600 m<sup>3</sup> of sand, with Dr Andrew Short [Coastal Studies Unit, Sydney University] estimating that the Manyana seawall

created a rip and additional erosion inland of the order of 10 m. A/Professor Doug Foster [Director of UNSW Water Research Laboratory at the time and recognised coastal engineering expert] agreed that a rip formed in the vicinity of the Egger property which allowed larger waves to reach it but did not regard the seawall as adding to the erosion.

Page 65-66: *“Most of the erosion which led to the collapse of the Egger home was due to the action of the major rip which was operating in the vicinity of that home. I am satisfied that the Manyana seawall was interacting with the waves, and that this interaction resulted in additional erosion in the area of the home. It is probable that without this additional erosion the Egger home would not have collapsed. ... If the erosion had halted five metres (and possibly even three metres) sooner the home would probably not have collapsed.” “The competing considerations were finely balanced.”*

Page 68-72: As to whether Council was guilty of negligence, *“... in 1968 a local council engineer would not have had the relevant coastal knowledge” “...It was necessary to distinguish between developed and undeveloped areas”*.

Page 75: *“However, I am far from convinced that a Council engineer and the Council in 1968, ... should have concluded that the execution of the work ... might result in beach erosion and danger either to Manyana or any neighbouring property.”*

Page 77: *“In June 1974 the Council was confronted with an emergency, requiring urgent action. Manyana had to be protected from the erosive effects of the sea.” “With hindsight and current knowledge a council may have permitted temporary holding measures ... then looked at the matter again ... and only approved a long term solution which would have no adverse effects on neighbouring properties”*.

Page 78: Smart noted: ***“... my conclusion that the seawall did have adverse effects was reached on the balance of probabilities. The balance was a fine one and it is not a case where I am certain that I am right. More research needs to be done in this field.”***

*“In 1968 and 1974 no council ... would reasonably have appreciated the matters litigated, ...”*

Three of the four expert witnesses (A/Prof Doug Foster, Mr Lex Nielsen and Mr Chris Brown) held the view that the Manyana seawall did not cause the rip that led to the collapse of the Egger home, but Dr Andrew Short held the view that it did.

Smart stated: *“I am of the opinion that the plaintiff has not made out a case in negligence against the council”*.

Page 79: *“The plaintiff’s property was worth \$59,500 and she sold the remains of her land for \$37,000 and thereby suffered a loss of \$22,500.”*

Page 84: *“If I had found in her favour I would have assessed her general damages at \$50,000 and treated \$35,000 of that sum as being damages to date.”*





Figure 3.1 Zoomed aerial view of subject properties (Horton, 2016)



**Figure 3.2 Collapse of house at 23b Ocean View Drive Wamberal in June 1978 (News Limited)**



Note: 33 Pacific Street (to its immediate left) having been relocated 10m landward

**Figure 3.3 Collapse of house at 23a Ocean View Drive Wamberal in June 1978**

## 3.2 Egger Case appeal

Supreme Court Of New South Wales Court Of Appeal, Hope (1), Samuels And Clarke (2) JJA, 588 Of 1987, 22, 23, 24, 27 June 1988, 10 March 1989, 40 Pages.

The judgement of Smart was reviewed. It examined foreseeability, duty of care, liability, proximity and negligence. The Court of Appeal concurred that Council was not negligent.

Mrs Egger was ordered to pay one half of the costs of the original hearing and the full costs of the appeal. That is, Council was ordered to pay half the costs of the original case because (page 38) it (Council) lost on one issue - the issue of causation.

Draft

## 4 WRL (1998) reports

### 4.1 WRL Technical Report 97/22 Design study

The WRL (1998) study undertook the following tasks:

- Assessment of various options for a “terminal protective structure” [essentially a mostly buried seawall/revetment]
- Community consultation
- Detailed design of the preferred option
- A parallel Environmental Impact Statement (EIS) undertaken by Manly Hydraulics Laboratory (MHL, 2003)

Based on studies available at the time, WRL adopted an underlying recession rate of 0.3 m/year from PWD (1995), which was attributed to either lagoon sinks, offshore sinks, sea level rise and/or aeolian losses. No attempt was made to quantify the relativity or magnitude of these potential loss mechanisms.

A design storm erosion volume of 250 m<sup>3</sup>/m above AHD was adopted from PWD (1995).

Design runup levels ranged from 6.4 to 8.2 m AHD from PWD (1995).

A design scour level of -1 m AHD was adopted for the present day, which was increased to -2 m AHD to account for ongoing recession over 50 years.

Design wave heights at the proposed seawall were calculated through a sequence of steps involving wave transformation and depth limitation utilising previous studies, with the results at the seawall (for -2 m AHD scour depth) shown in Figure 4.1.

Five options were considered, namely:

- Sloping, two layer basalt armour (Figure 4.2, Figure 4.3)
- Sloping, two layer sandstone armour (Figure 4.4)
- Vertical contiguous concrete piles (Figure 4.5, Figure 4.6)
- Sloping Seabee armour with gabion/reno mattress toe (Figure 4.7, Figure 4.8)
- Sloping Seabee armour with vertical contiguous pile toe (Figure 4.9)

Council and the community chose the option of a sloping Seabee armour with gabion/reno mattress toe (Figure 4.7) with an estimated costs of:

- \$7.2 million total for a length of 1360 m, equating to:
- \$5,300 per metre of foreshore
- \$90,000 for a 17 m property frontage

The construction period was estimated to be 15 months.

A preliminary alignment of the structure was developed, which considered the natural alignment of the bay, existing buildings and a 3 m maintenance corridor.

Based on separate physical modelling, the following crest levels were adopted (Figure 4.10):

- Chainage 0 to 18 m, Terrigal Lagoon area: 4.0 to 6.0 m AHD
- Chainage 17 to 391 m, Southern end of beach: 7.0 m AHD
- Chainage 391 to 399 m, Central part of beach: 7.0 to 8.0 m AHD
- Chainage 399 to 1307 m, Central to northern part of beach: 8.0 m AHD

- Chainage 1307 to 1319 m, northern part of beach: 8.0 to 6.0 m AHD
- Chainage 1319 to 1350 m, Wamberal SLSC and car park: 6.0 m AHD

Draft

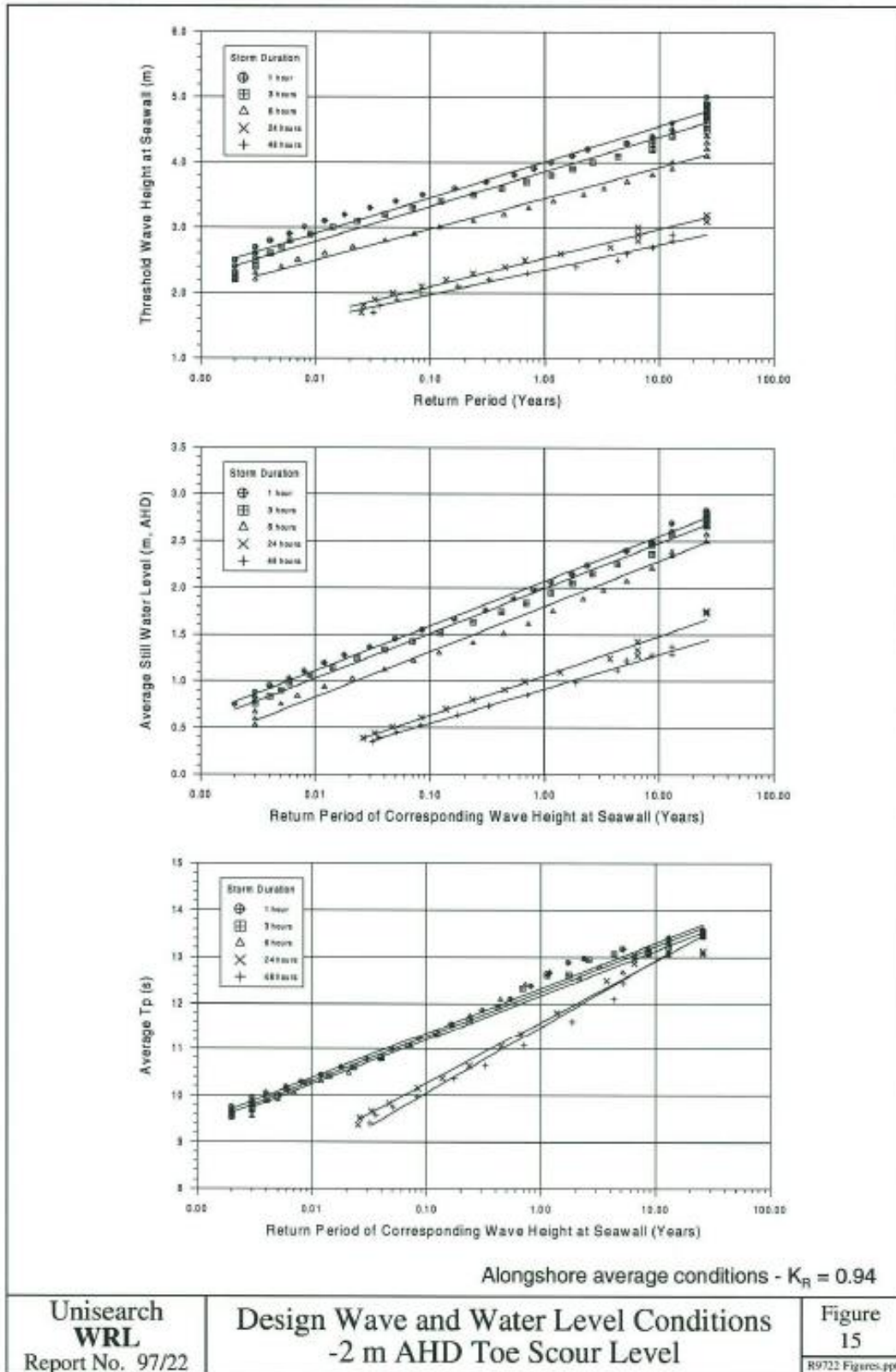
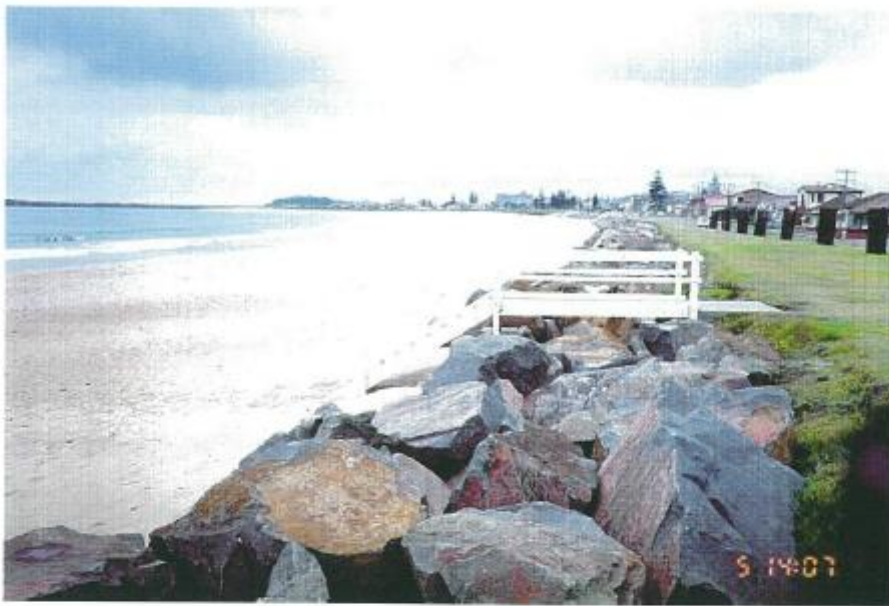


Figure 4.1 Nearshore waves and water levels for -2 m AHD scour level (WRL Figure 15)



**a) Typical Pre-Storm Conditions**



**b) Typical Post-Storm Conditions**

*\* It is noted that this structure has been designed for significant wave overtopping.*

Unisearch <b>WRL</b> Report No. 97/22	Typical Basalt Armoured Revetment Stockton Beach NSW	Figure 17 <small>R0722 Figures.ppt</small>
---	---	--

**Figure 4.2 Basalt option**

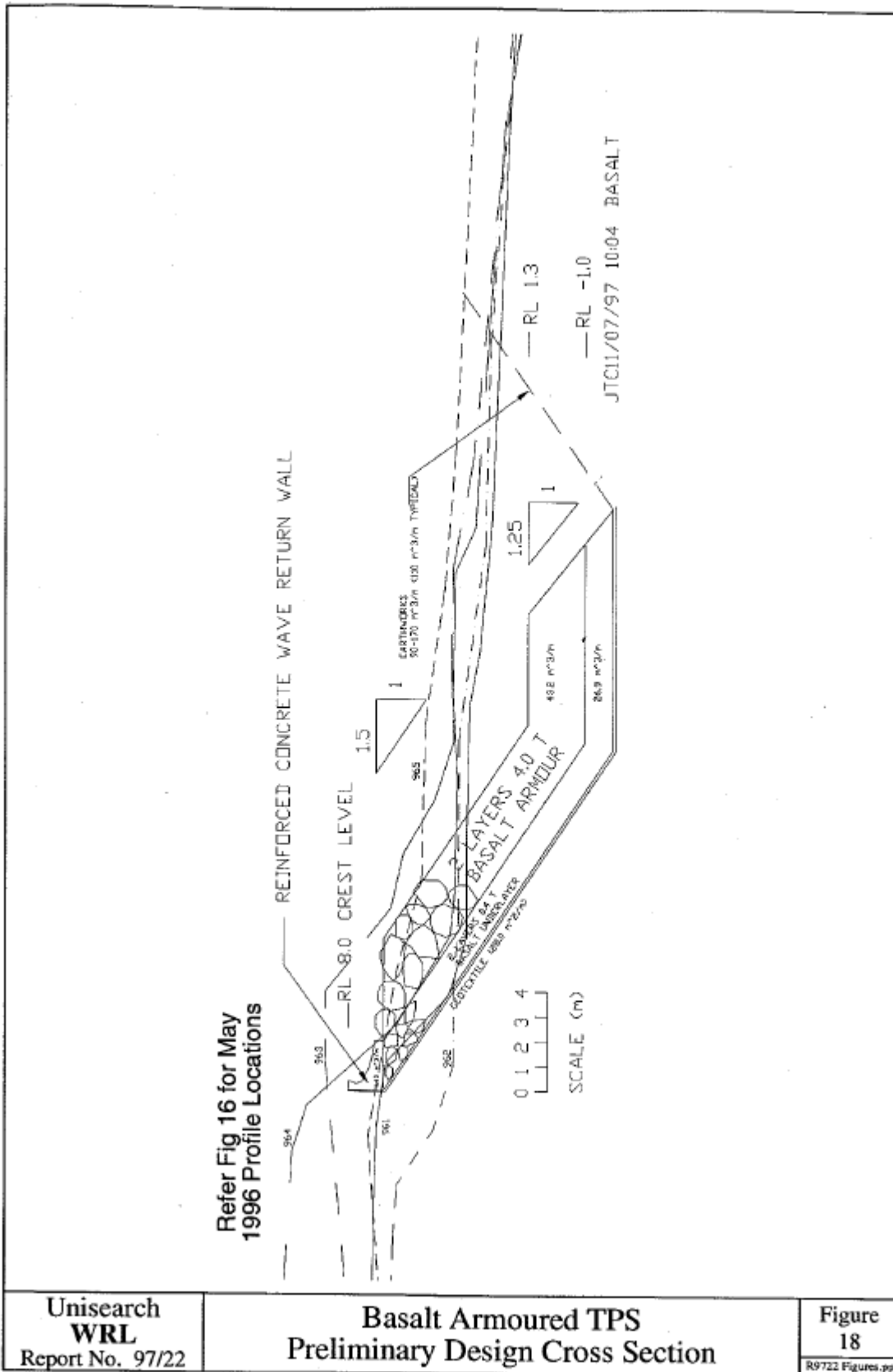


Figure 4.3 Basalt cross section



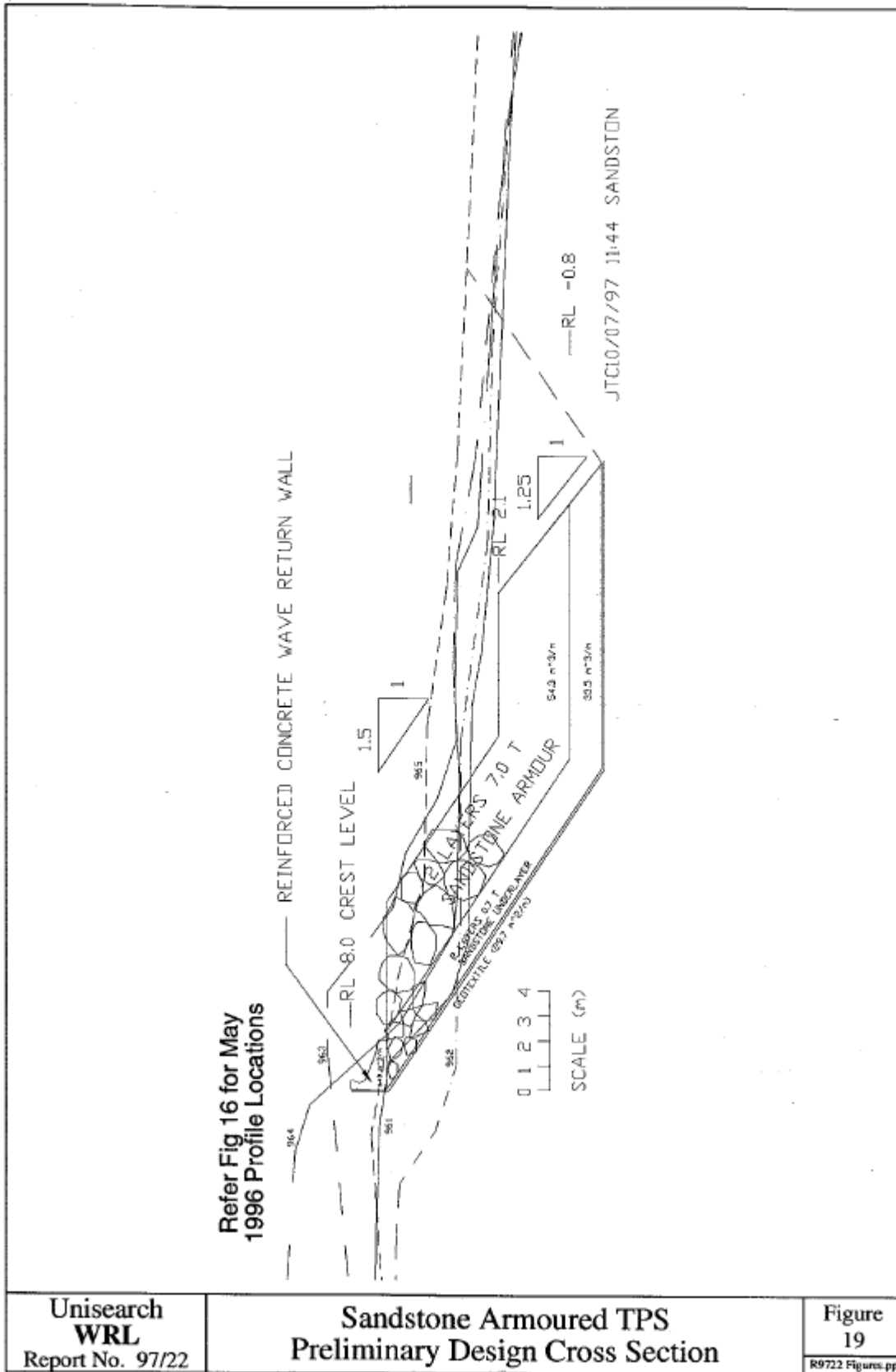


Figure 4.4 Sandstone cross section

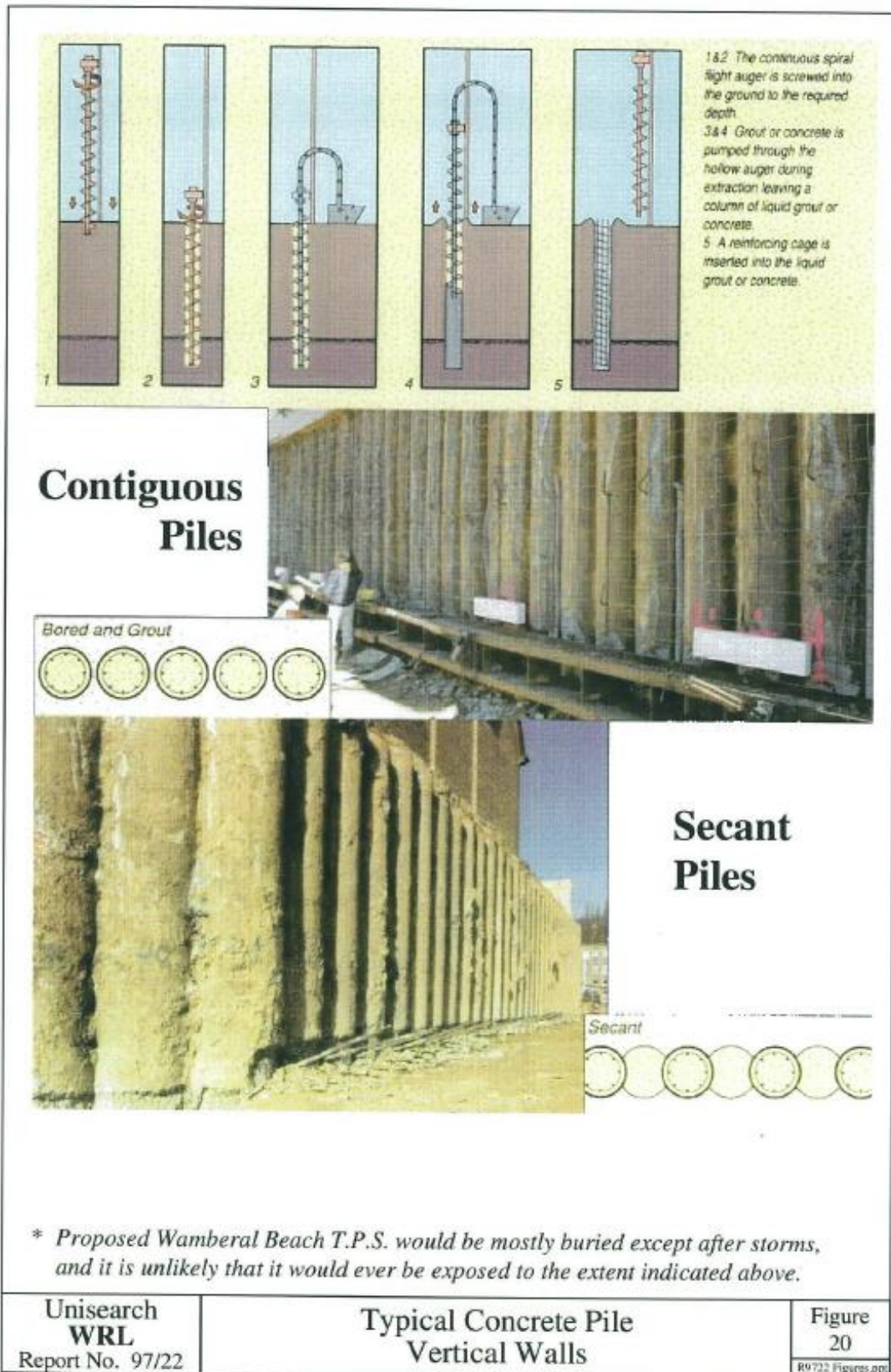


Figure 4.5 Concrete pile option

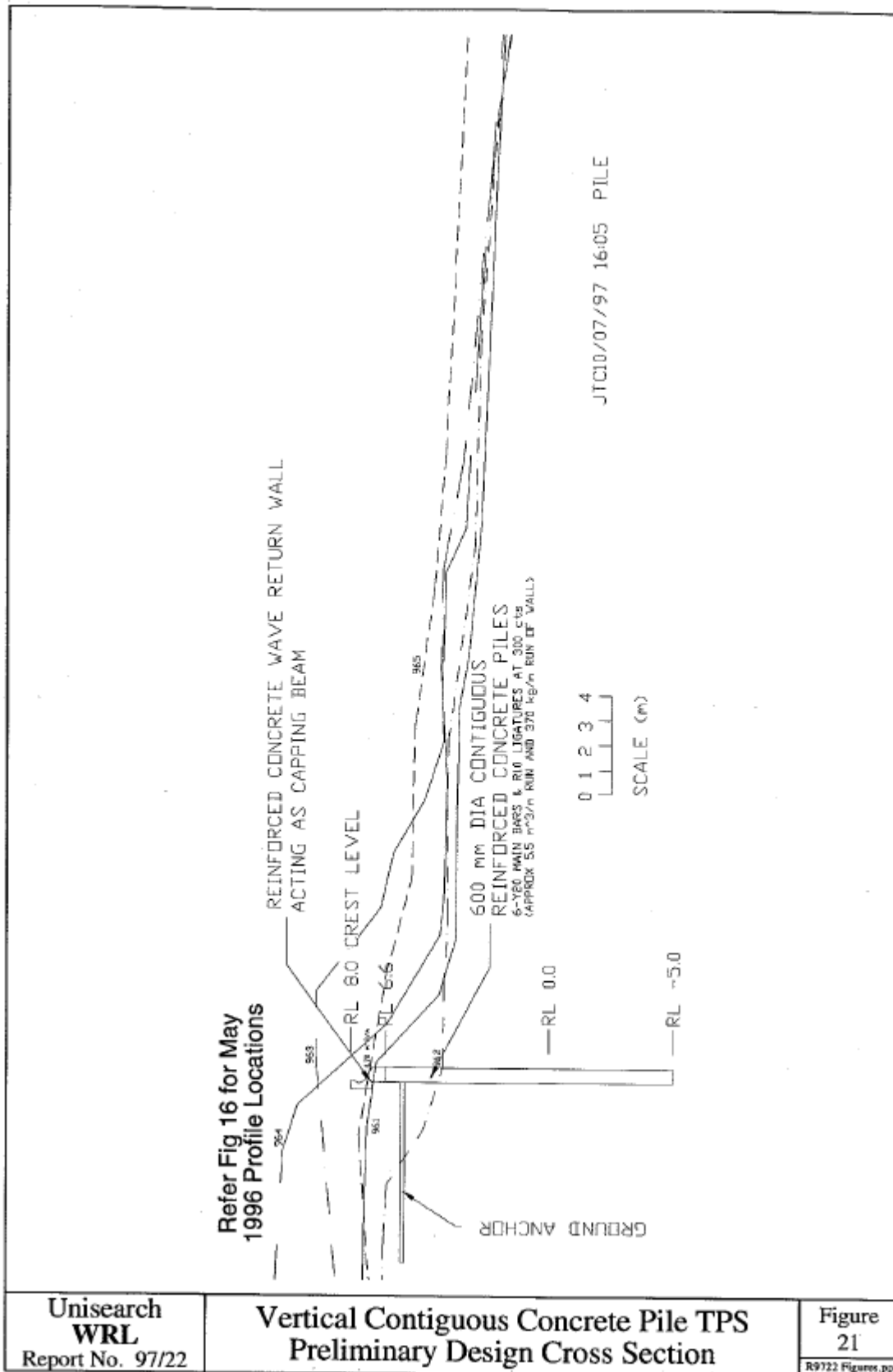


Figure 4.6 Concrete pile cross section

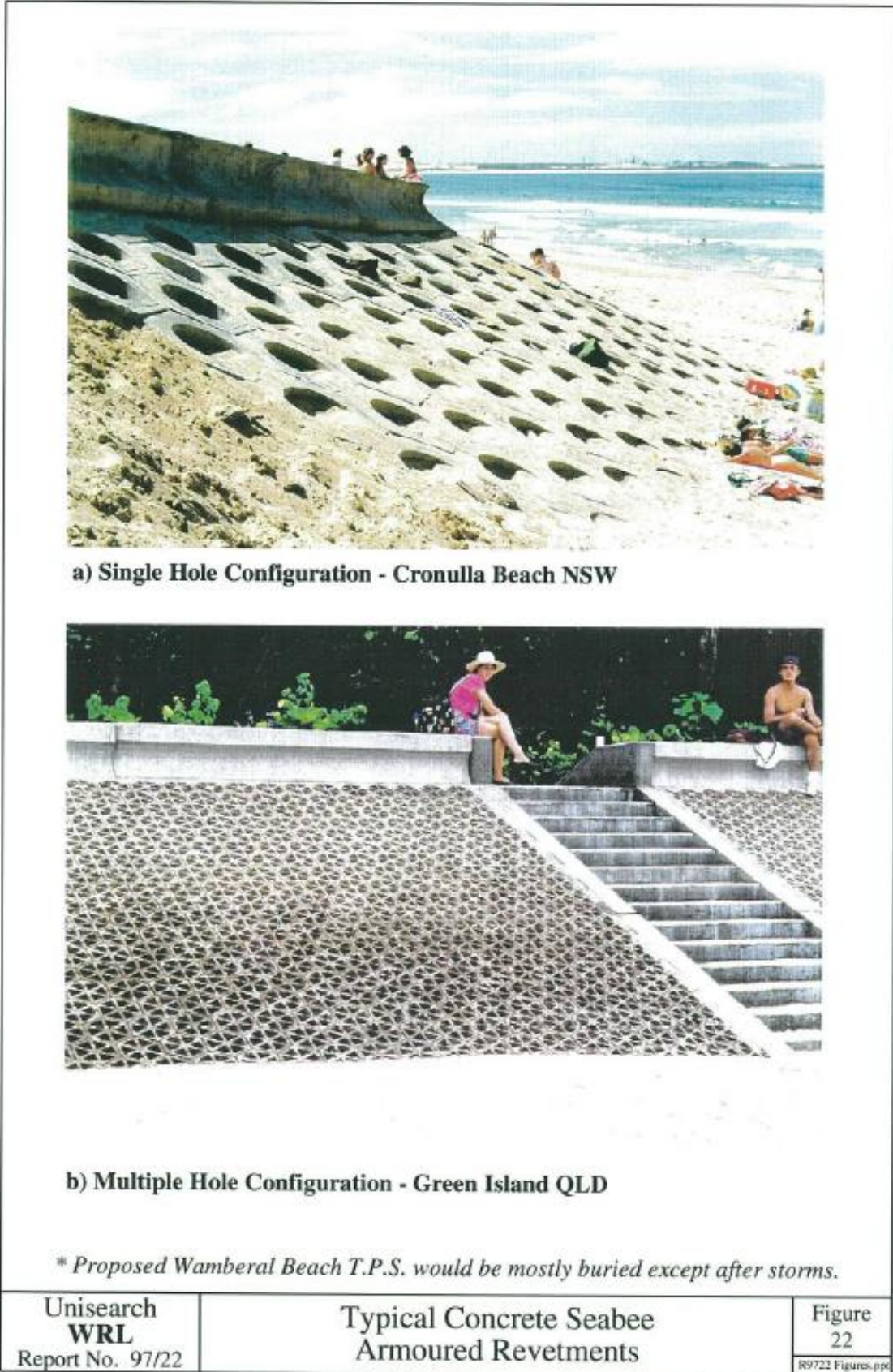
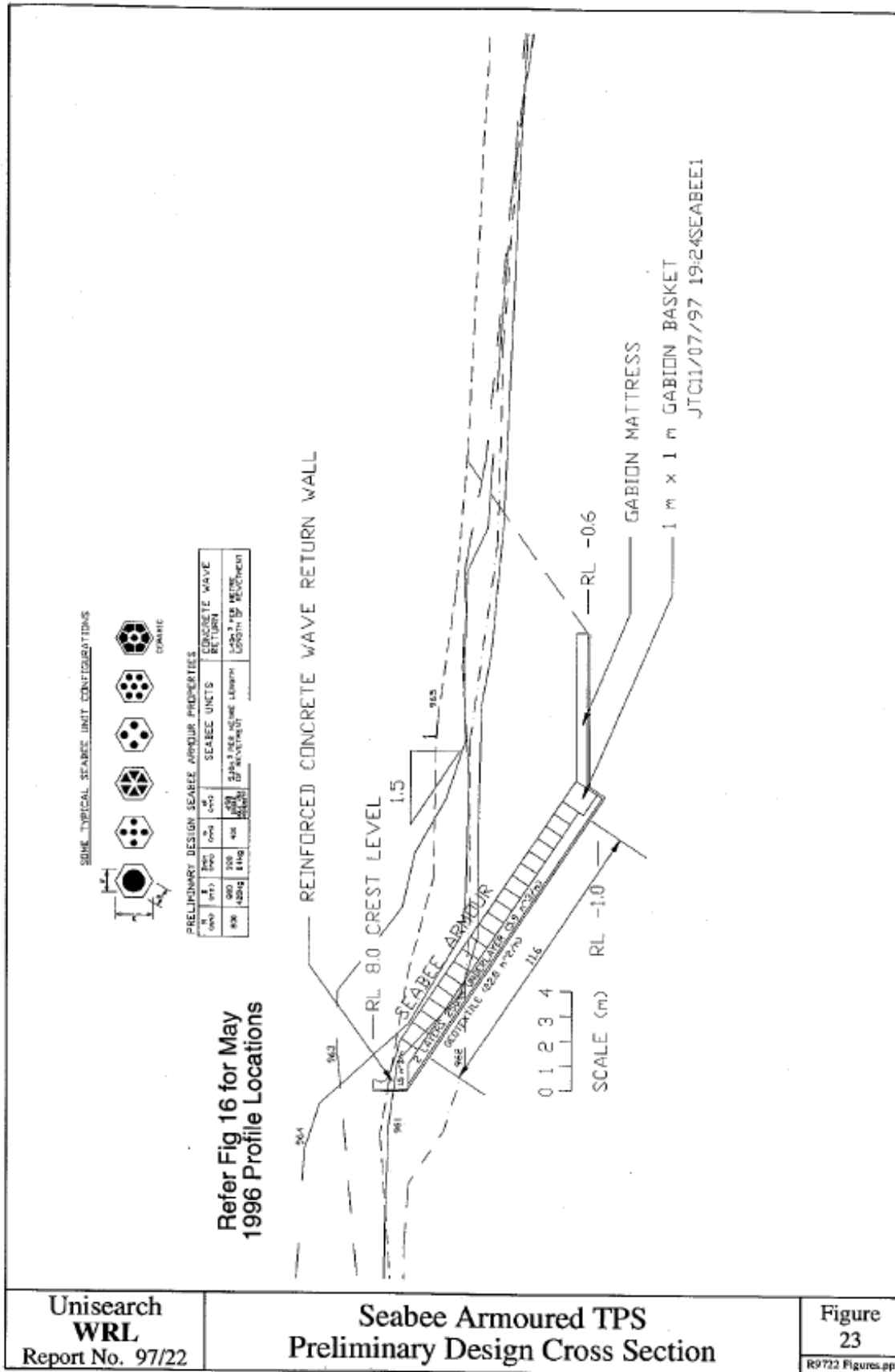


Figure 4.7 Seabee option



Unisearch  
WRL  
Report No. 97/22

Seabee Armoured TPS  
Preliminary Design Cross Section

Figure  
23

R9722 Figures.ppt

Figure 4.8 Seabee cross section

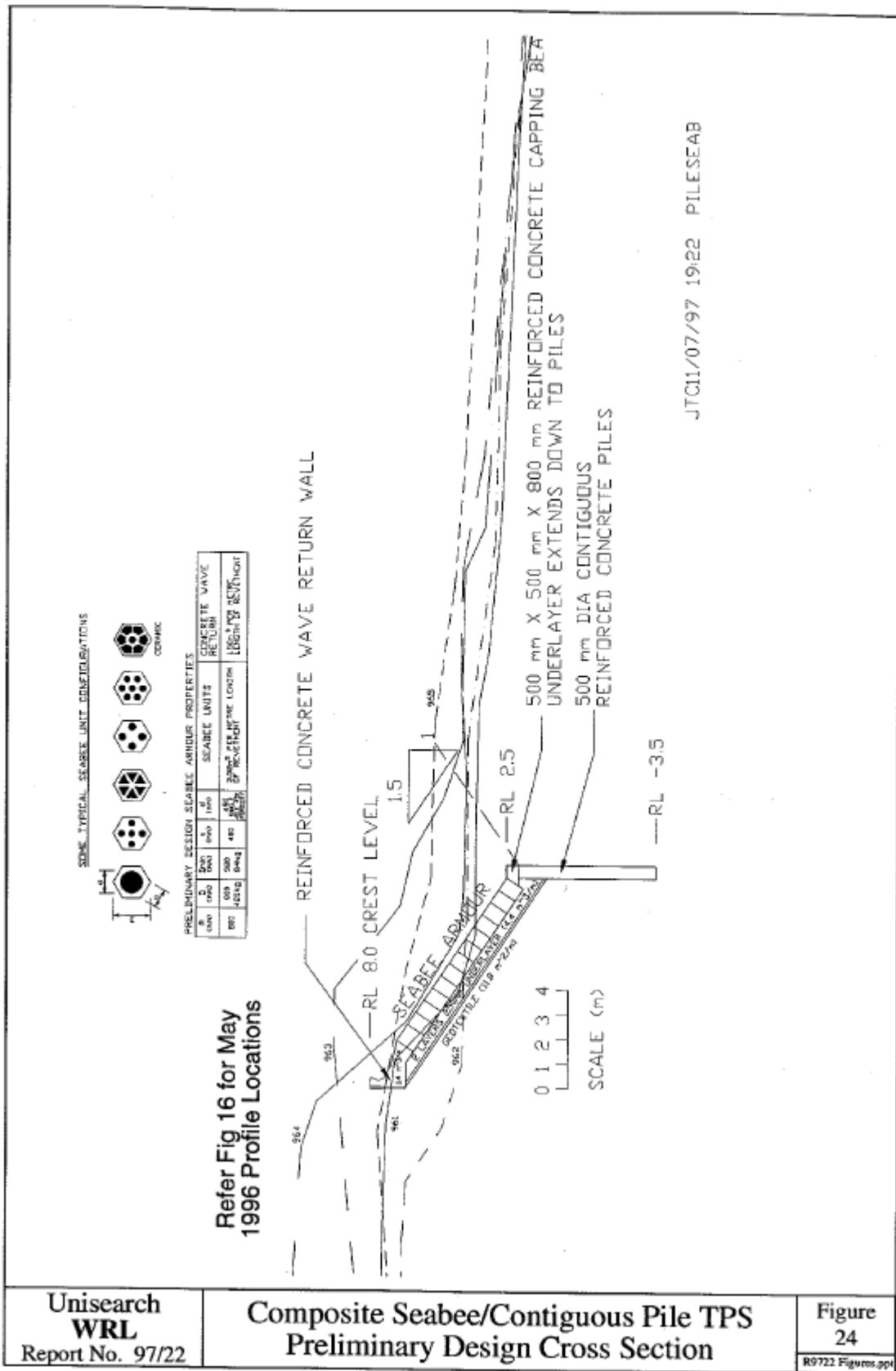


Figure 4.9 Seabee with piled toe cross section

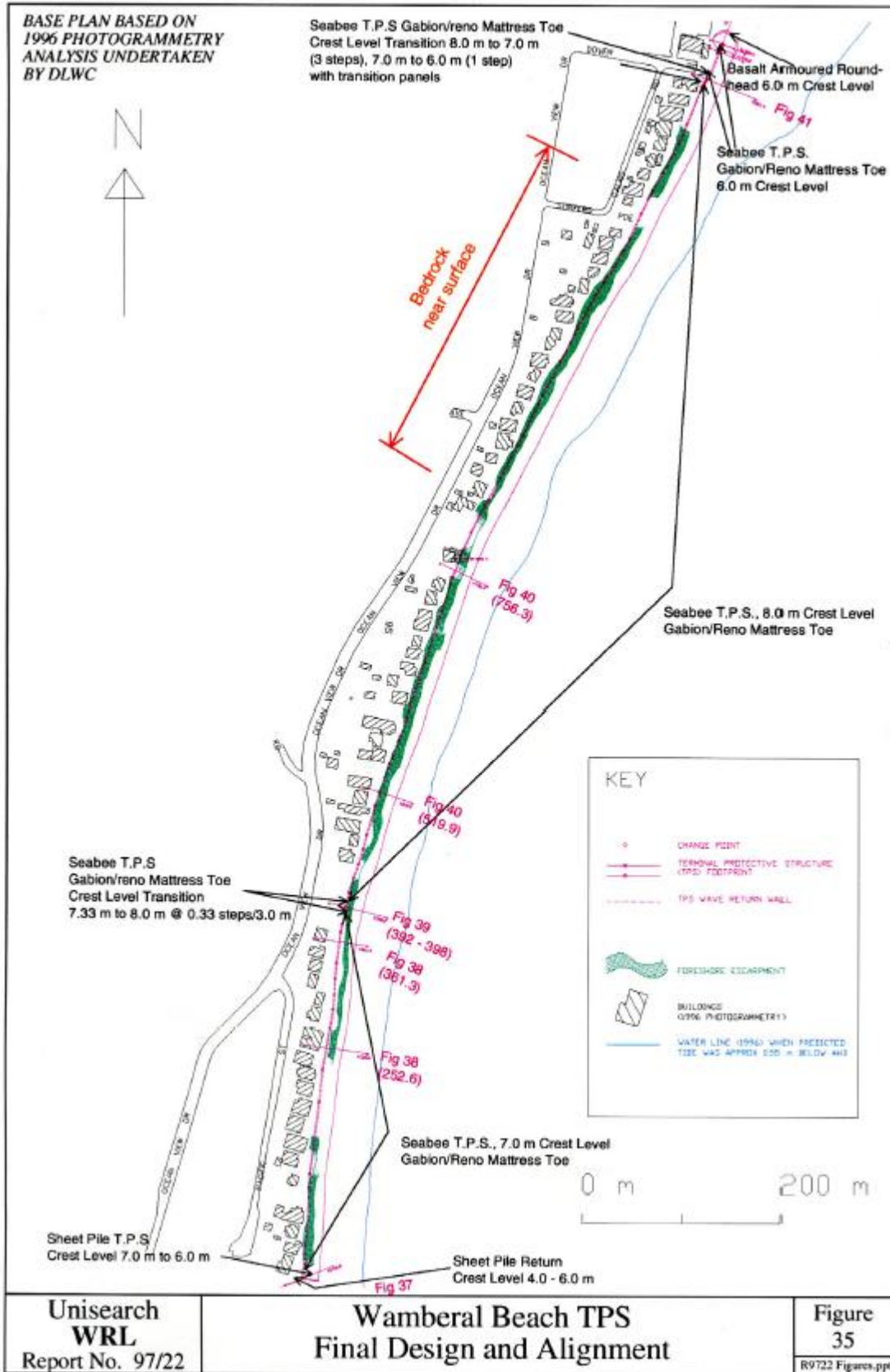


Figure 4.10 Adopted alignment

## 4.2 WRL Technical Report 97/26 Physical modelling study

Physical modelling was undertaken for the preferred Seabee option at a length scale of 1:28.

The design tested is shown in Figure 4.8, with photos of the model in Figure 4.11 to Figure 4.14.

For an assumed bed scour level of -1 m AHD (present day design scour), the following design conditions at the structure were tested:

- 100-year ARI:
  - $H_s = 2.82$  m
  - $T_p = 14.4$  s
  - Still water level including wave setup = 3.0 m AHD

The Seabees adopted (Figure 4.15) were 800 mm in diameter and 800 mm deep, with an inner diameter of 480 mm, and a mass of 365 kg each.

To reduce wave overtopping, three wave return wall geometries were tested (Figure 4.16), with designs B and C found to have acceptable wave overtopping performance with a crest level of 8 m AHD.

With a scour level fronting the structure of -1 m AHD (present day), the structure could not be failed, due to the depth limited wave conditions. The structure could be failed by simulating future beach recession with the toe being founded in “several metres water depth”.

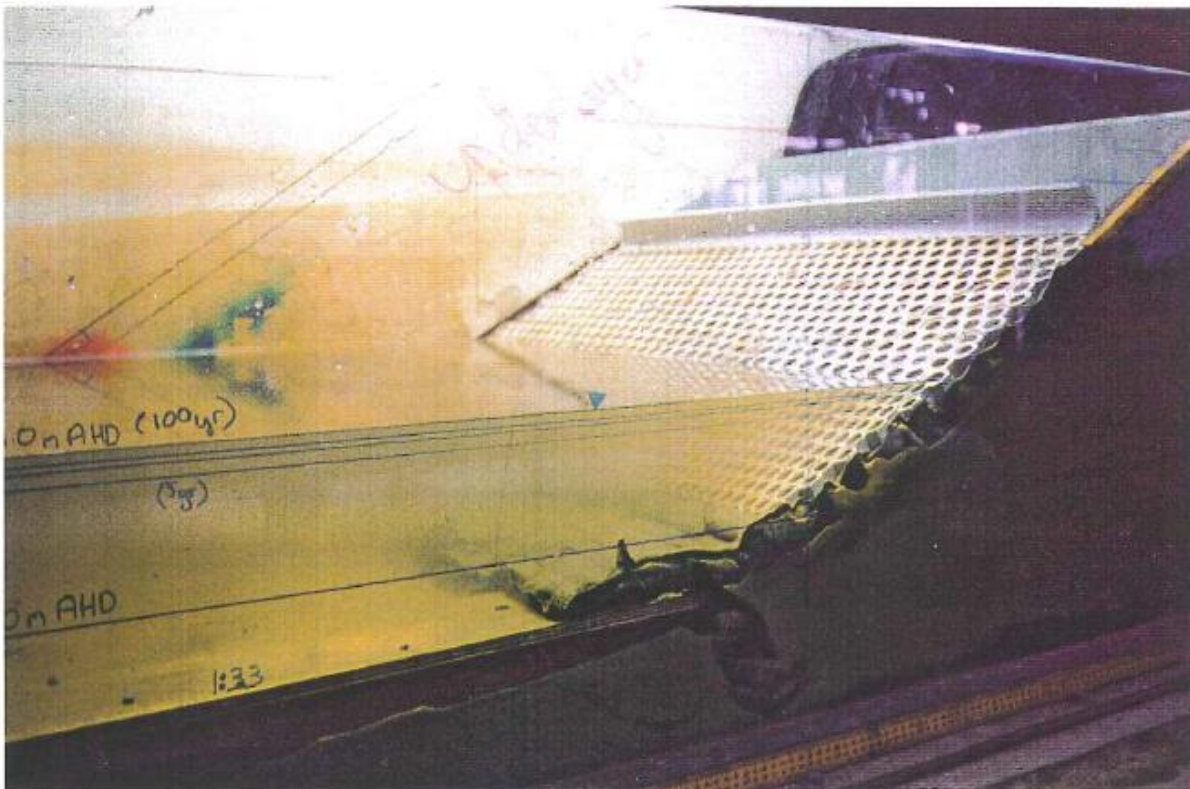


Figure 4.11 Oblique view of Seabees in flume





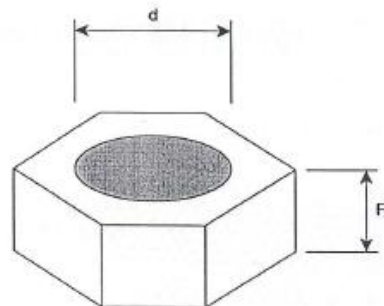
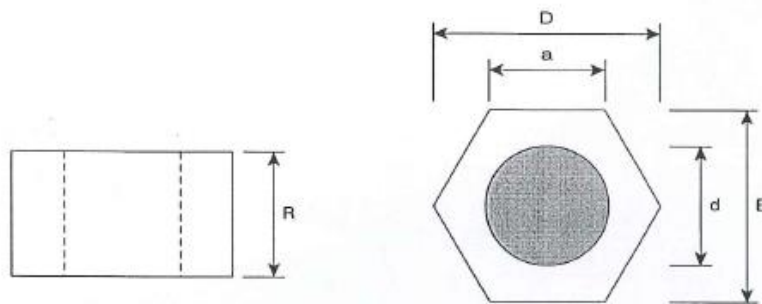
Figure 4.12 Overhead view of Seabees in flume



Figure 4.13 Side view of wave runup

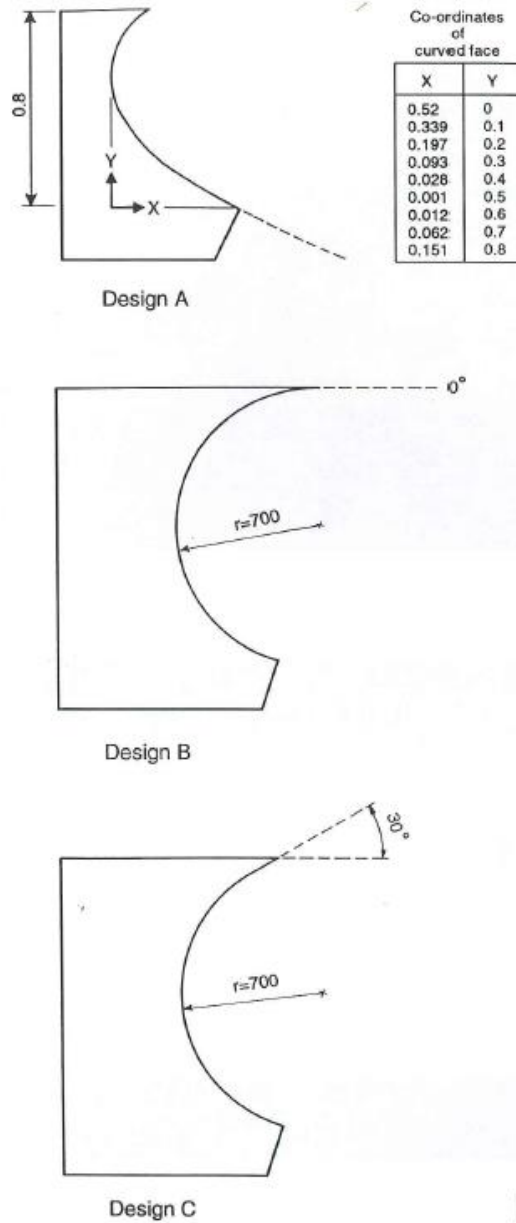


Figure 4.14 Overhead view of wave runoff



Cell aspect ratio =  $R/d$

Figure 4.15 Seabee configuration



**Figure 4.16 Wave deflector geometry**

## 4.3 WRL Technical Report 98/05 Wamberal Beach terminal protective structure - Technical specification

This report (144 pages) provided a technical specification for the Seabee seawall, including ancillary works.

It also included a 65 page report by John P Hudson of Coastal and Marine Geosciences (1997) entitled Gosford City Council open beaches geotechnical investigations (Avoca Beach, Wamberal Beach, Forresters Beach).

## 5 MHL (2003) Seawall Environmental Impact Statement

Wamberal Beach and property protection: Environmental Impact Statement (2003), MHL Report MHL935, DPWS Report 98047, ISBN 0 7313 0716 X, 145 pages.

MHL (2003) examined the Seabee seawall proposal in detail. It noted that there were no known indigenous archaeology constraints on the proposed seawall.

The following options/alternatives were examined in detail:

- Planning controls
- Planned retreat
- Terminal protection
- Piled foundations
- Dune management

Recent innovations such as reefs were canvassed but considered inappropriate. Several unproven “*alternative*” technologies were also dismissed.

The only two large scale options considered were nourishment and terminal protection. Nourishment as a standalone option was found to be a viable option, but the lack of a known source prevented it being an option at the time.

It noted (page 60): “*At the present time the only viable options for the protection of the existing development along Terrigal/Wamberal would appear to be through the construction of a terminal protection structure*”.

While periodic nourishment was proposed in addition to the seawall, an appropriate sand source had not been identified.

## 6 MHL (2004) Realignment and Cost Review

*MHL, (2004). Coastal Engineering Advice - Realignment and Cost Review of Wamberal Terminal Protection Structure and Beach Nourishment. Letter Report CME6-00156. Dated 15 July 2004. 27 Pages.*

In 2004 MHL was commissioned by Gosford City Council to determine the realignment of the proposed WRL (1998) seawall design along Wamberal Beach due to the constructions of a new residential development at 17 Calais Rd, Wamberal. The work included:

- site inspection to assess extent of the existing (as of 2004) protection and possible works required to remove or incorporate the existing protection in the new structure.
- Amendment to the 1998 TPS plans to cater for necessary realignment of the structure due to recent redevelopment at 17 Calais Road, Wamberal (the redevelopment was within the proposed setback limit from the TPS).
- Assessment of the implications of any realignment of the TPS.
- Confirmation of secured sand supply from the Stockton dunes for beach nourishment for five years and updated costs for the supply, delivery and periodic placement of suitable nourishment sand along Wamberal Beach.
- Preparation of drawings of the realigned TPS suitable for presentation to Environmental Impact Statement consent authorities.
- Evaluation of present-day (2004) costs to construct the TPS.

The proposed design realignment is shown in Figure 6.1 and Figure 6.2, proposing that a 120 m section of the TPS at the northern end, between 9 Calais Rd and Wamberal Surf Club, be realigned up to 5m seaward of the original design due to redevelopment at 17 Calais Rd. The realignment was designed to achieve sufficient setback for a design wave overtopping of 4 L/m/s from WRL (1998). The crest elevation transition from 8 m AHD to 7mAHD was also moved slightly north as part of the study as shown in Figure 6.1.

Costs to construct the seawall were revised from \$7.2 million (WRL,1998) to \$8.2 million as part of the 2004 study. Updated costs included estimated costs included:

- the quantity of concrete for the wave return wall - reduced from 2040 m<sup>3</sup> to 1305 m<sup>3</sup>;
- cost of Reno mattress – increased from \$450/m to \$600/m;
- cost of Gabion basket – increased from \$120 to \$200 each;

The study also identified that additional costs would be required for the removal of ad-hoc protection (as of 2004) works not considered in 1998 design costings. Eleven properties at the time were identified to have ad-hoc protection requiring removal estimated at \$30,000 per property, with removal of additional buried protection works not quantified. Costs for further investigation using ground-penetrating radar to identify buried ad hoc protection structures along Wamberal Beach was estimated at \$30,000.

Indicative costs to supply 20,000 m<sup>3</sup> per year of beach nourishment sand from Stockdon dunes to Wamberal Beach were estimated at \$760,000/year however suppliers at the time were unable to guarantee the supply for a period of five years.

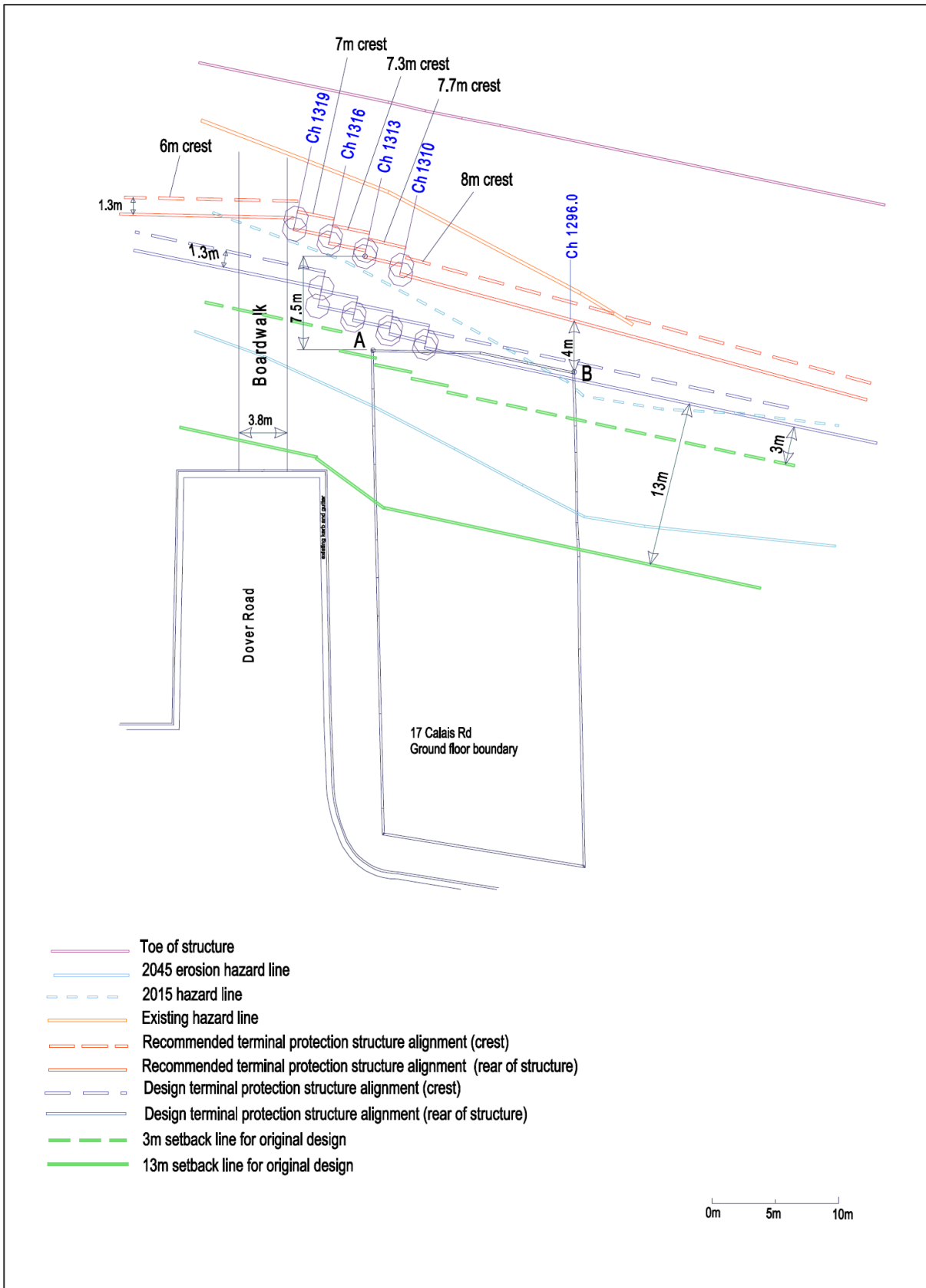


Figure 6.1: Recommended Terminal Protection Structure crest and rear alignment from MHL (2004)

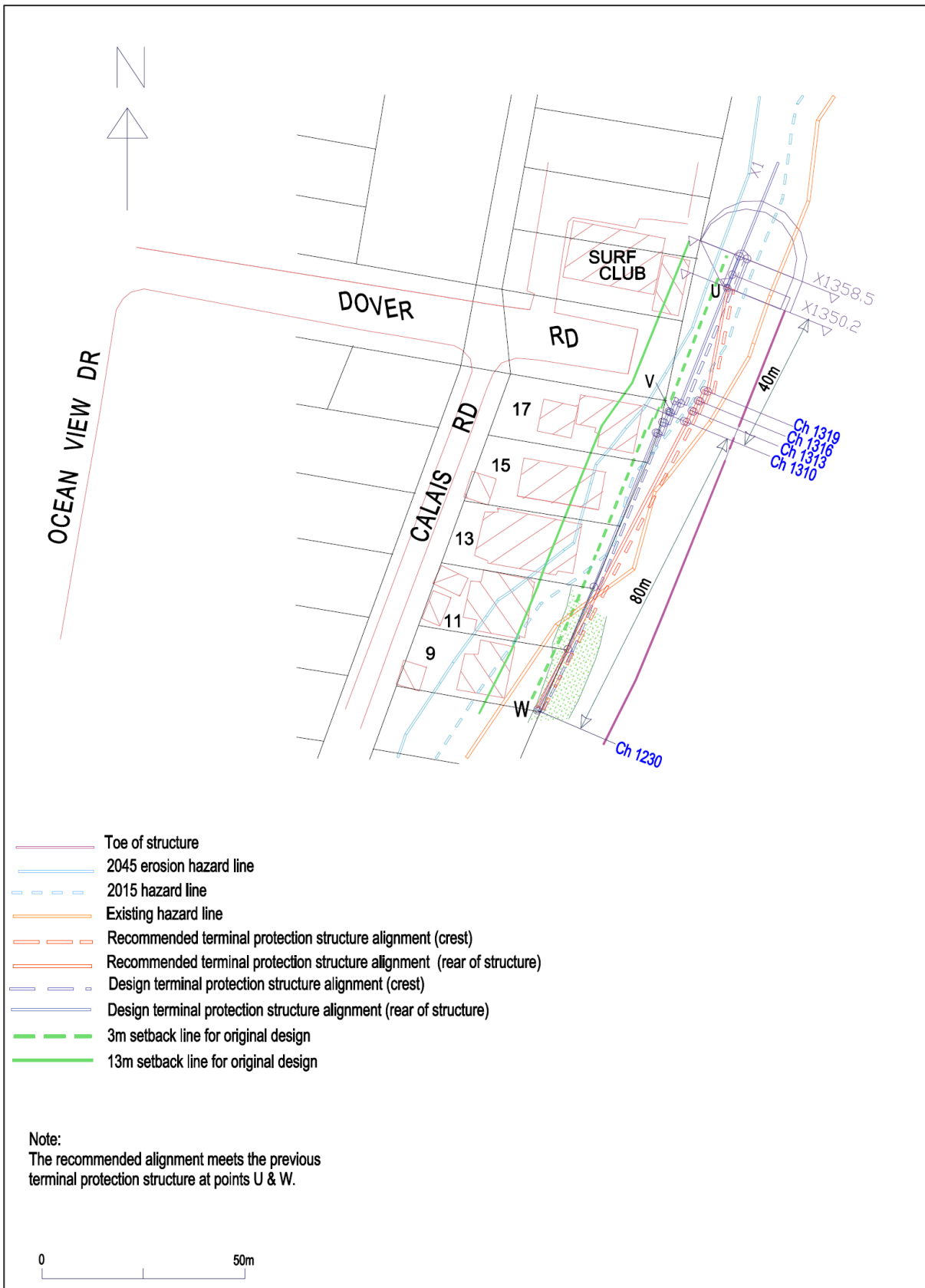


Figure 6.2: Recommended Terminal Protection Structure crest and toe realignment from MHL (2004)

## 7 WorleyParsons (2014) Coastal hazard definition study

### 7.1 WorleyParsons (2014) body

WorleyParsons (2014) is entitled: Gosford City Council open coast and Broken Bay beaches Coastal processes and hazard definition study (136 pages plus appendices). Only the portions relevant to Wamberal have been summarised in this review.

WorleyParsons (2014) was published in five (5) revisions (A to E), spanning from 11 November 2011 to 24 February 2014.

#### 7.1.1 Coastal hazards

WorleyParsons acknowledged that there were portions of rock outcrops and many ad-hoc seawalls, however, coastal hazards for Wamberal were calculated on the basis of sandy profiles. Conversely, for Terrigal, the presence of rock headlands/cliffs and engineered seawalls meant that these features were assumed to be the landward limit of coastal hazards. Therefore no coastal hazard lines were produced for Terrigal.

The following coastal hazard components were estimated:

- Sea level rise in accordance with the state “benchmarks” which prevailed at the time:
  - 2050: 0.4 m relative to present
  - 2100: 0.9 m relative to present
- “Design” (nominally 100 year ARI) storm demand:
  - Terrigal Blocks 1 to 2 (Figure 7.5): 60 to 140 m<sup>3</sup>/m moving north
  - Wamberal Blocks 4 to 7 (Figure 7.6): 250 m<sup>3</sup>/m
- Recession due to sediment budget deficit (0.2 m/year for Wamberal):
  - Wamberal 2050: 8.8 m
  - Wamberal 2100: 18.8 m
- Recession due to sea level rise:
  - Wamberal 2050: 14.6 m
  - Wamberal 2100: 36.1 m
- Wave setup was estimated as 15% of the design significant wave height for each beach, with the following 100 year ARI water levels:
  - Wamberal still water level (tide plus surge): 1.4 to 1.5 m AHD
  - Wamberal wave setup: 1.0 m
- Wamberal wave setup level (tide + surge + setup): 2.5 m AHD
- “Design” wave runup level:
  - Terrigal-Wamberal south: 4.0 m AHD
  - Terrigal-Wamberal central: 6.0 m AHD
  - Terrigal-Wamberal north: 7.0 m AHD

#### 7.1.2 Coastal hazard lines

The cross section used for defining coastal hazard lines is shown in Figure 7.1. Surface hazard lines depicting the landward limit of the Zone of Slope Adjustment (ZSA) and Zone of Reduced Foundation Capacity (ZFRFC) are shown in Figure 7.2 and Figure 7.3. It should be noted that the hazard lines ignore existing ad-hoc protection works and rock outcrops, and will be located further



landward in the future due to underlying recession and sea level rise.

WorleyParsons (2015) noted the following regarding the hazard lines:

- As at 20 January 2010, there were 69 private lots fronting Wamberal Beach, with 68 occupied by a dwelling/building
- 61 dwellings have some portion seaward of the Immediate ZSA, with the 6 dwellings that are located entirely landward of the Immediate ZSA
- 65 dwellings have some portion seaward of the Immediate ZRFC, with the 2 dwellings that are located entirely landward of the Immediate ZRFC
- 24 dwellings have a substantial proportion of their footprint seaward of the Immediate ZSA
- Wamberal SLSC is located entirely landward of the Immediate ZSA and ZRFC, so is at relatively low risk from coastal erosion at present.

Lots potentially affected by coastal hazards to 2100 are show in Figure 7.4.

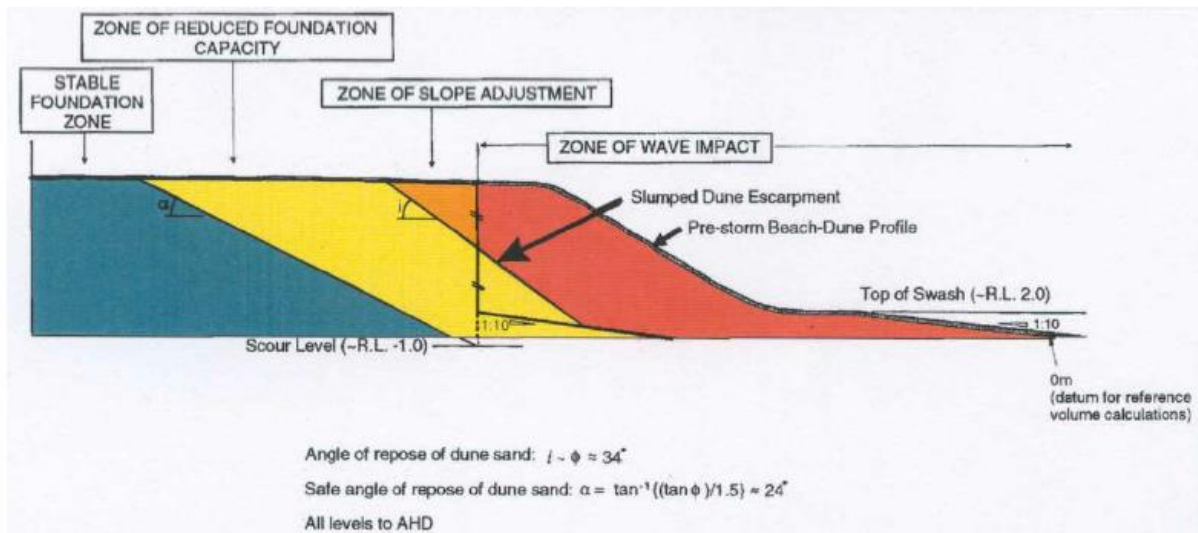


Figure 7.1 Dune stability cross section (WP Figure 46)

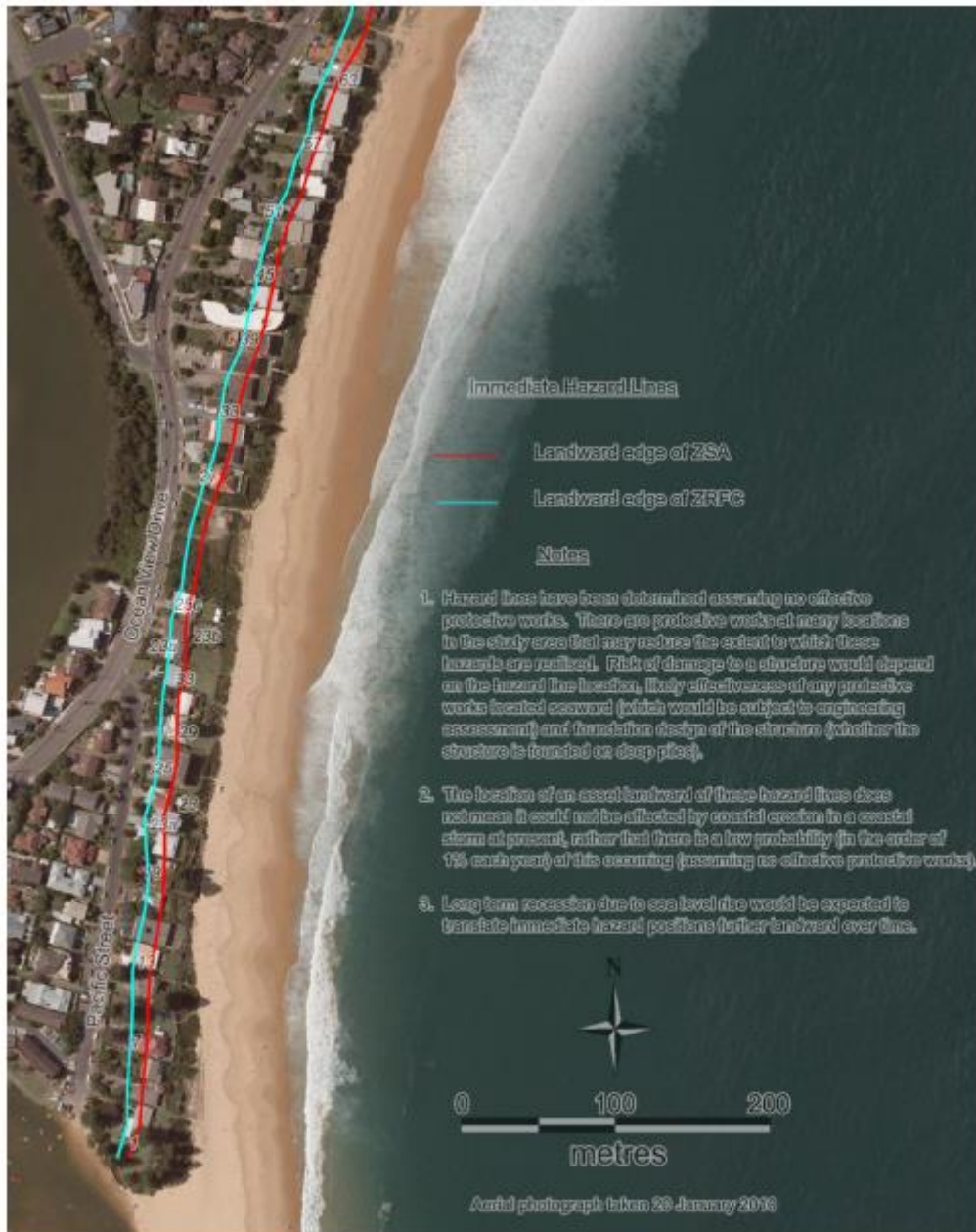


Figure 21: Immediate Coastline Hazard Lines at landward edge of Zone of Slope Adjustment (ZSA) and Zone of Reduced Foundation Capacity (ZRFC) in southern half of study area (ignoring protective works)

Figure 7.2 Present day coastal hazard lines – south (WP, 2015 Figure 21)



Figure 22: Immediate Coastline Hazard Lines at landward edge of Zone of Slope Adjustment (ZSA) and Zone of Reduced Foundation Capacity (ZRFC) in northern half of study area (ignoring protective works)

Figure 7.3 Present day coastal hazard lines - north (WP, 2015 Figure 21)



Figure 7.4 Lots potentially affected by coastal hazards (WP, 2015 Figure A3.7)

### 7.1.3 Lagoon processes

Wamberal and Terrigal lagoons are actively managed due to the need for flood mitigation of surrounding property and infrastructure. WorleyParsons reported on lagoon processes predominantly from previous studies such as Cardno Lawson and Treloar (2010).

The following statistics were reported for Wamberal and Terrigal lagoons for the period 1976 to 2007:

- Average mechanical openings per year:
  - Wamberal: 2.7
  - Terrigal: 12.6
- Average Duration Entrance Open (days):
  - Wamberal: 10
  - Terrigal: 8
- Managed berm height (m AHD):
  - Wamberal: 2.6 to 2.7
  - Terrigal: 1.7
- Trigger level for entrance opening (m AHD):
  - Wamberal: 2.4
  - Terrigal: 1.23

WorleyParsons reported that an estimated 1 million kg of sediment per year infills the four coastal lagoons (Terrigal and Wamberal, plus Avoca and Cockrone). This is equivalent to about 600,000 m<sup>3</sup>/year, or an average of 150,000 m<sup>3</sup>/year per lagoon. Infill from the ocean is also a natural geological process, but would likely be lower than the present rate. The lagoons are generally a sink rather than source of sand for the surrounding beach.

## 7.2 WorleyParsons (2014) Appendix H

WorleyParsons (2014) Appendix H is entitled: *Analysis of photogrammetric data – Terrigal-Wamberal* (25 pages).

The photogrammetry transects and blocks are shown in Figure 7.5 and Figure 7.6.

WorleyParsons examined photogrammetry from the following dates, with other important notes listed after the date:

- 25 November 1941 (Low accuracy)
- 16 May 1954
- 4 June 1965
- 6 July 1969
- 29 October 1973
- 19 June 1974 (Taken immediately following major storm)
- 9 January 1977
- 2 August 1978 (Taken immediately following major storm)
- 29 September 1985
- 18 August 1986 (Taken immediately following major storm)
- May 1990
- 20 April 1993

- 30 May 1996 (Not analysed in PWD, 1994)
- 26 March 1999 (Not analysed in PWD, 1994)
- 6 March 2006 (Not analysed in PWD, 1994)
- 3 July 2008 (Inaccurate data - discarded from analysis)

The typical swash zone slope was found to be 1V:11H at Wamberal.



Figure 7.5 Photogrammetry blocks 1 to 5 (WP Figure H1)



**Figure 7.6 Photogrammetry blocks 5A to 8 (WP Figure H2)**

### 7.2.1 Recession

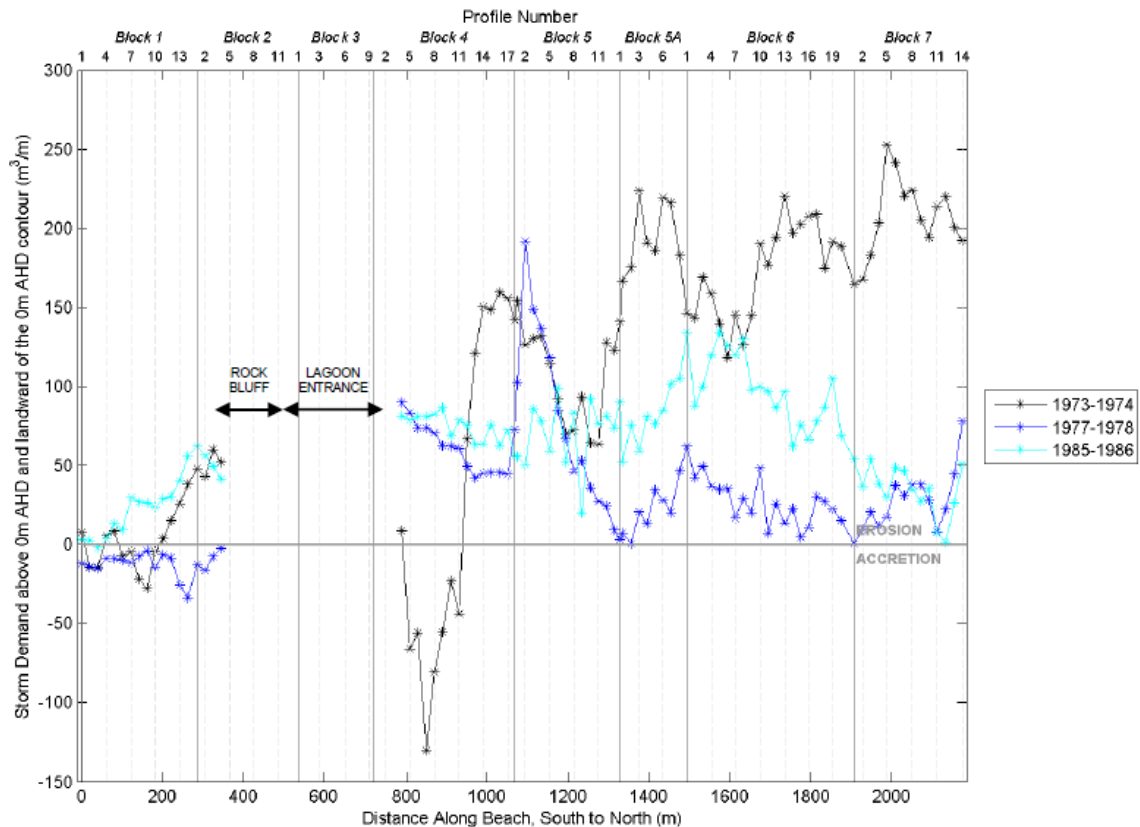
WorleyParsons made the following observations regarding long term change:

- Most profiles are subject to anthropogenic modification
- Blocks 5, 5A and 6 had higher rates of recession, typically 0.2 m/year
- Blocks 4 and 7 were generally stable or slightly accreting
- Historic sea level rise (SLR) can account for recession of 0.043 m/year (1 mm/year SLR with Bruun Factor of 43)
- **A design recession rate of 0.2 m/year was recommended**

## 7.2.2 Storm erosion

WorleyParsons made the following observations regarding storm erosion based on analysis of the photogrammetry:

- There were three major storm events captured in the photogrammetry, with alongshore volume change shown in Figure 7.7:
  - October 1973 to June 1974 (May-June 1974 storm event)
  - January 1977 to August 1978 (June 1978 storm event); and
  - September 1985 to August 1986 (August 1986 storm event).
- Peak storm erosion of 250 m<sup>3</sup>/m above AHD was measured at Block 7, Profile 5 in the May-June 1974 storms
- Peak storm erosion of 190 m<sup>3</sup>/m above AHD was measured at Block 5, Profile 2 in the June 1978 storm
- Storm erosion of 100 m<sup>3</sup>/m above AHD was measured along much of Wamberal in the August 1986 storm
- The 2006 profile was selected as the “average beach full” (accreted profile) for determining coastal hazard lines
- No evidence of beach rotation was observed, so no allowance was made for this



**Figure 7.7 Alongshore volume change (WP Figure H8)**



## 8 WorleyParsons (2015) Coastal management study

This report canvasses management options for all open coast beaches in the former Gosford local government area. This review relates primarily to areas relevant to the concept design of a seawall.

### 8.1 Summary of previous studies

Section 2.3.8 details some history of Terrigal-Wamberal Beach, with a focus on Terrigal. It notes that Wamberal SLSC was formed in 1950.

Section 2.4.1.1 notes that there are 10 Aboriginal sites recorded in or near Terrigal-Wamberal Beach and Forresters Beach.

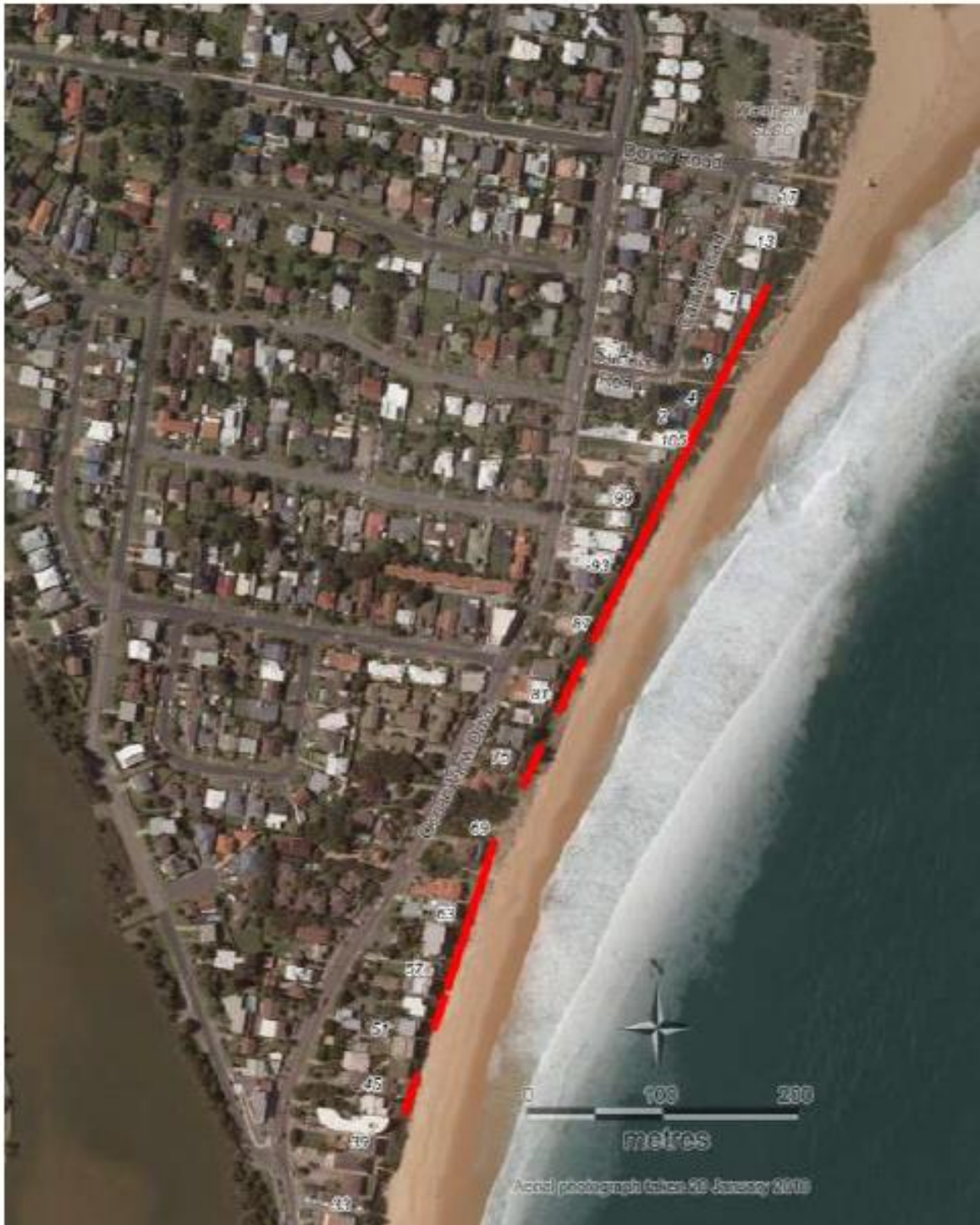
Section 3 summarises Gosford Development Control Plan 2013 which includes Wamberal, including the requirement for a 3 m maintenance corridor for a proposed future seawall.

Section 4 summarises the coastal processes presented in WorleyParsons (2014).

Section 5 summarises the coastal hazards presented in WorleyParsons (2014).

Section 6.8 regarding existing management measures for Terrigal-Wamberal noted:

*“Protective action taken in the 1970's has resulted in the dune sand in the vacant 'Pye' properties (Lots 10-11, DP 12022 No.s 71 and 69, Ocean View Drive, Terrigal) to be replaced with solid fill. This solid fill would act as a solid barrier in the event of dune erosion and recession (WBM & Planning Workshop, 1995). PWD (1985) noted that virtually all beachfront development at Wamberal Terrigal Beach was threatened from severe erosion in the 1974 storms, and that the State Emergency Service and Australian Army were called in and tipped rocks, sand bags and other materials seaward of the eroding dune face. Beachfront property owners also constructed a variety of structures in response, comprising rock rubble, corrugated iron, rubber tyres, besser blocks, concrete walls and gunite (cement, sand, and water applied through a pressure hose). Areas along Wamberal Beach known to have rock protective works placed in June 1974 are shown in Figure 39.”* (reproduced as Figure 8.1).



**Figure 8.1 Extent of rock protection works placed in 1974 (WP, 2015, Figure 39)**

Section 7 discussed numerous management options. With regard to groynes they noted:

*“Groynes are not expected to be very effective for the beaches within Gosford LGA as they work best in areas where there is a strong rate of longshore drift, which is not the case for most of the beaches in Gosford. For this reason, groynes have not been considered in detail when discussing appropriate management measures at each beach.”*

With regard to artificial reefs they noted:

*“Artificial Reefs are not a practical option for the beaches in Gosford – because of their high cost and the difficulty in predicting their effectiveness.”*

Within Section 7.13 on funding, they provided an example that if 30% of properties were not owner occupied, and had an average UCV of \$2 million, the annual land tax revenue would be \$530,000. While not noted by WP, over 50 years, with a 7% discount rate, this has a present value of \$7.3 million.

For comparative costing of all options for all beaches in the study area, WP Section 8.3 used the assumptions in the following section.

## 8.2 Assumptions for Costing of Options

*“An indicative capital cost has been provided for each option and the cost is based on the following assumptions:*

- *Sand nourishment*
  - *The quantity of sand nourishment is assumed to be the design storm demand above 0 m AHD as per the Coastal Processes and Hazard Definition Study (WorleyParsons, 2014);*
  - *Sand nourishment at a rate of \$25/m<sup>3</sup>;*
  - *Mobilisation and demobilisation of plant for sand nourishment operation at \$200,000;*
  - *Nourishment campaign would need to be periodically repeated and so there is a recurrent cost associated with this – we have assumed for the purposes of providing a Net Present Value cost to 2050 that the exercise would need to be repeated on average once every 10 years.*
- *Beach scraping*
  - *Beach scraping volume of 8 m<sup>3</sup>/m, which is approximately equal to a scraping depth of 0.2 m (Carley et al., 2010).*
  - *The recommended beach scraping depth is less than 0.5 m and effects on intertidal species such as pipis can be minimised by using a shallow scraping depths of approximately 0.2 m (Carley et al., 2010).*
  - *Beach scraping at a rate of \$8/m<sup>3</sup>. This is based on the adopted rate for beach scraping from the Carley et. al. (2010) escalated to 2014;*
  - *There is a recurrent cost associated with beach scraping which has been included in the Net Present Value cost to 2050, with the exercise typically undertaken every two years on average.*
  - *Stabilisation of dunes with vegetation and associated fencing and accessways at a rate of \$45/m<sup>2</sup>. There is also a recurrent cost associated with this option which has been taken into account in the Net Present Value to 2050.*
- *Erosion protection works:*
  - *Erosion protection works for exposed areas at a rate of \$10,000/m;*
  - *Erosion protection works for less exposed areas, such as shallow depth areas or within lagoons or lakes, at a rate of \$4,000/m; and*
  - *“tripper” structure to control opening location of creek at a rate of \$2,000/m.*

- *Infrastructure repair or relocation:*
  - *Carpark or road repairs to pavement following inundation at a rate of \$80/m<sup>2</sup> (source: Council Infrastructure Planning department);*
  - *Road relocation at a rate of \$150/m<sup>2</sup>, subject to geotechnical conditions and exclusive of property resumption (source: Council Infrastructure Planning department);*
  - *Reconstruct pavements using materials resistant to erosion and inundation damage – 30% additional construction cost (source: Council Infrastructure Planning department);*
  - *Pumping station and surf club relocation or redevelopment at a rate of \$1,500/m<sup>2</sup>;*
  - *Restaurants relocation or redevelopment at a rate of \$2,000/m<sup>2</sup>; and*
  - *Relocation of sewer or water infrastructure at a rate of \$400/m.*
- *Stormwater works:*
  - *Scour protection design and construct \$50,000 per outlet (source: Council Infrastructure Planning department);*
  - *Relocation of stormwater outlet \$50,000 per outlet (source: Council Infrastructure Planning department).*
- *Dune Management:*
  - *Council allocation for Dunecare for works supervision \$5,000 p.a. per location (source: Council);*
  - *Dunecare dune vegetation management works \$10,000 - \$20,000 p.a. per location (source: Council)."*

### 8.3 Net present value costings

*"Net present value costings utilised the following assumptions:*

*Probability of damage seaward of Immediate ZSA = 2% p.a.*

*Probability of damage seaward of 2050 ZSA = 1% p.a.*

*Probability of damage seaward of Immediate Wave Impact Zone = 3% p.a.*

*Probability of damage to unprotected properties seaward of immediate ZSA and adjacent to properties with ad-hoc protection = 5% p.a.*

*Risk of damage seaward of 2050 ZRFC for buildings not piled = 1% p.a. x \$1 million*

*Damage potential for existing buildings piled but within wave impact zone = \$100,000*

*Damage potential for redeveloped buildings piled but within wave impact zone = \$150,000*

*Value of minor structures seaward of building subject to storm damage = \$50,000*

*Property values estimated as per [www.onthecorner.com.au](http://www.onthecorner.com.au)*

*Cost of terminal protection = \$10,000/m + 1% maintenance cost p.a.*

*Properties purchased at full market value 10% of property value costed for purchase of an easement for alternative access*

*Environmental damage and social impacts not costed as insufficient data is available to assign a dollar value to these items. Based on previous studies (SA Department of Environment and Heritage 2005) the value to the local economy of a beach visit is approximately \$5 per visit and this has been included in the costs and benefits where appropriate.*

*Beach scraping done bi-annually; reduces risk of erosion and inundation by 50%*

*Beach nourishment needs to be repeated every 10 years but is effective in reducing coastal hazard risk.*

*Loss of development potential at a lot either through erosion or application of development controls reduces property value by 10%.*

*Inundation is assumed to cause 15% damage to housing with 1.0 m average overfloor depth.*

*Shifting of the burden of rate income to the broader community has been estimated for the voluntary purchase options based on average rate figures provided by Council, with an assumed 3% p.a. increase. This cost has been included in the net present costs for the voluntary purchase options.*

*There will also be a loss of income to the NSW Government associated with the purchase of beachfront property - due to a loss of land tax revenue from those beachfront investment properties that have an unimproved capital land value over \$432,000”*

## 8.4 Attempt at securing a funding agreement

With regard to funding a seawall at Wamberal, WP (p282) noted:

*“On the 30 March 2006, the Mayor, the General Manager and Council's Principal Environmentalist met with the Minister Kelly along with his Policy Adviser on Emergency Services. At the meeting Council presented a detailed briefing paper. In summary, the briefing paper requested:*

*Funding assistance of a one off request of \$2.8 million from the State Government towards the construction of an \$8.2 million terminal protection structure (seawall) along Wamberal Beach. Council is seeking a similar financial assistance from the Federal Government of \$2.8 million and intends to seek the balance of \$2.8 million from the 78 residential properties that front Wamberal Beach to cover the total project cost of \$8.2 million. The estimated cost for the construction of the Wamberal TPS in 2014 would be approximately \$10.5 million.*

*In addition to the construction cost Council was seeking an ongoing commitment of approximately \$380,000 towards periodic sand nourishment which is currently estimated at \$760,000. Council has since endeavoured to source grant funds through the State's Coastal Management Program and the Federal Government's Natural Disaster Mitigation Program. Council has also lobbied State and Federal governments, however, all efforts to secure financial assistance for the project have been unsuccessful.”*

## 8.5 Emergency action plan

Terrigal-Wamberal was divided into six precincts, namely:

- Precinct 1 – Terrigal Haven
- Precinct 2 – Terrigal Beach;
- Precinct 3 – Terrigal Lagoon to Wamberal Beach;
- Precinct 4 – Wamberal Beach;
- Precinct 5 – Wamberal Lagoon; and
- Precinct 6 – North Wamberal Beach.

An Emergency Action Subplan was also presented, which involved sand filled geotextile containers or imported sand.

## 8.6 Major options considered for Wamberal

Major options considered for Terrigal-Wamberal (WP Table 29) that are relevant to the present Wamberal project include:

- Beach nourishment to increase buffer against storm erosion (TW1.3)
  - Capital cost \$1 to 1.5 million, Costs NPV \$2.3 to 3.4 million, Benefits of enhanced amenity
- Allow lagoon frontage properties at southern end of Pacific Street to self protect (TW3.2)
  - Capital cost \$250,000 per property, Costs NPV \$93,000 per property, Benefits NPV \$93,000 per residence (reduction in erosion damage of \$250,000 per property, probability of occurrence of 1% p.a.), BCR 1.0
- Beach scraping from lagoon entrance to reduce erosion and inundation risk to properties at southern end of Pacific Street (TW3.3)
  - \$50,000 p.a., Costs NPV \$700,000, Benefits NPV \$280,000 (reduced risk of damage), BCR 0.4
- Allowing development landward of the 2050 Zone of Slope Adjustment with piled foundations into the 2100 Stable Foundation Zone (TW4.1)
  - Capital cost N/A, Costs NPV \$37 million, Benefits NPV Up to \$47.5 million, BCR 1.28
- Allowing development landward of a specially defined building line or Immediate Zone of Slope Adjustment with piled foundations into the 2100 Stable Foundation Zone (TW4.2)
  - Capital cost N/A, Costs NPV \$39.6 million, Benefits NPV Up to \$47.5 million, BCR 1.20
- Allow residents to construct own permanent protection works combined with existing DCP controls (TW4.4):
  - Capital cost \$43 million, Costs NPV \$64.2 million, Benefits NPV Up to \$26 million, BCR 0.40
- Terminal protection (TW4.5)
  - Capital cost \$13 to 15 million, Costs NPV \$20.4 million, Benefits NPV Up to \$47.5 million, BCR 2.33
- Planned retreat from this area, through voluntary purchase of properties where buildings are seaward of 2050 Zone of Slope Adjustment. (TW4.6)
  - Capital cost \$304 million, Costs NPV \$319 million, Benefits NPV Up to \$47.5 million, BCR 0.15
- Voluntary purchase of properties where buildings are seaward of Immediate Zone of Slope Adjustment (i.e. 61 properties) (TW4.7)
  - Capital cost \$244 million, Costs NPV \$259 million, Benefits NPV Up to \$44 million, BCR 0.17
- Beach nourishment to increase buffer against storm erosion (TW4.9)
  - Capital cost \$8.5 to 10 million, Costs NPV \$19.5 to 23 million, Benefits NPV Up to \$47.5 million, BCR 2.0

## 8.7 Consultation

Section 9 noted that five community workshops were held regarding the management study. Total attendance was 269. Average attendance was 54, with 51 attending the workshop for Terrigal-Wamberal-Forresters. A total of 56 written submissions were received, with six from Wamberal.

## 8.8 Excluded options

Section 9 page 304 noted: “The exhibited Draft Study merely presents a range of feasible options and does not recommend options or specifics associated with building lines.”

The following options (page 346) were excluded for Wamberal:

- Allowing development landward of the 2050 Zone of Slope Adjustment with piled foundations into the 2100 Stable Foundation Zone (TW4.1)
- Allow residents to construct own permanent protection works combined with existing DCP controls (TW4.4)
- Planned retreat from this area, through voluntary purchase of properties where buildings are seaward of 2050 Zone of Slope Adjustment. (TW4.6)
- Voluntary purchase of properties where buildings are seaward of Immediate Zone of Slope Adjustment (i.e. 61 properties) (TW4.7)
- Beach nourishment in front of carpark (TW5.3)
- Future relocation of surf club and carpark to an area landward of the coastal hazard area (TW5.5)

## 8.9 Beach usage statistics

Appendix 2 presented beach usage statistics from patrolled Gosford beaches which are reproduced for Terrigal-Wamberal in Table 8.1. It does not state whether these were from volunteer weekend patrols or paid weekday lifeguards, or both. These statistics probably don't consider after hours and out of patrol season use.

**Table 8.1 Beach usage statistics**

Month	Terrigal	Wamberal	Terrigal-Wamberal
<b>September 2014</b>	36,350	10,575	46,925
<b>October 2014</b>	59,980	13,269	73,249
<b>November 2014</b>	64,430	14,073	78,503
<b>December 2014</b>	105,260	18,450	123,710
<b>January 2015</b>	142,780	32,955	175,735
<b>February 2015</b>	45,860	13,280	59,140
<b>March 2015</b>	45,100	18,840	63,940
<b>April 2015</b>	20,650	4,190	24,840
<b>Total</b>	520,410	125,632	646,042

## 9 CZMP (2017) Gosford Beaches Coastal Zone Management Plan

WorleyParsons (2017), Gosford Beaches Coastal Zone Management Plan 301015-03417 – 003 3 April 2017.

The Gosford Beaches Coastal Zone Management Plan (CZMP) was certified by the Minister for the Environment in May 2017.

### 9.1 Major action items for Wamberal

For Wamberal, 18 management actions are listed. The major actions relevant to this project are:

- *“TW11 Terminal protection - Council to action review, design and funding of terminal protection structure for Wamberal. Cost \$200,000 to review and update existing design, \$13 million to \$15 million environmental assessment and construction cost plus 1% p.a. maintenance. To be funded by Council, State Government, Private, and/or Federal Government.”*
- *“TW14 Investigate sources of sand and feasibility of beach nourishment for Wamberal Beach. Investigation of feasibility \$50,000. Could be done as part of a city-wide study. To be funded by Council and State Government.”*
- *“TW15 Beach nourishment coupled with a terminal revetment to increase buffer against storm erosion. Investigation of feasibility \$50,000. Beach nourishment could be investigated in the review of the revetment design and environmental approvals. Beach nourishment cost estimate approximately \$1 million. To be funded by Council, State Government.”*
- *“TW25 Investigate purchase of small section of southernmost property (1 Pacific Street) to provide public access along lagoon frontage. To be negotiated with owner. Funding by Council.”*
- *“TW27 Erosion protection works to be allowed for properties. Works may comprise similar design to existing adjacent works. Works could be considered to be emergency works if they are in line with the requirements of the Code of Practice under the Coastal Protection Act. No cost allocated in CZMP. Private funding.”*

### 9.2 Consultation

Five community drop in sessions were held for the entire LGA, with total attendance of 85, and 17 (20%) people attended the session for Terrigal-Wamberal-Forrester.

### 9.3 Hazard lines

The study also published hazard lines for 2100 (Figure 9.1), and included GIS plots of the stormwater (Figure 9.2), and water and sewerage system (Figure 9.3), which showed that (unlike some areas) most of the system was landward of beachfront buildings.





Notes: Orange solid line is 2100 Stable Foundation Zone

**Figure 9.1 2050 and 2100 coastal hazard lines (WP, 2017, page 431)**

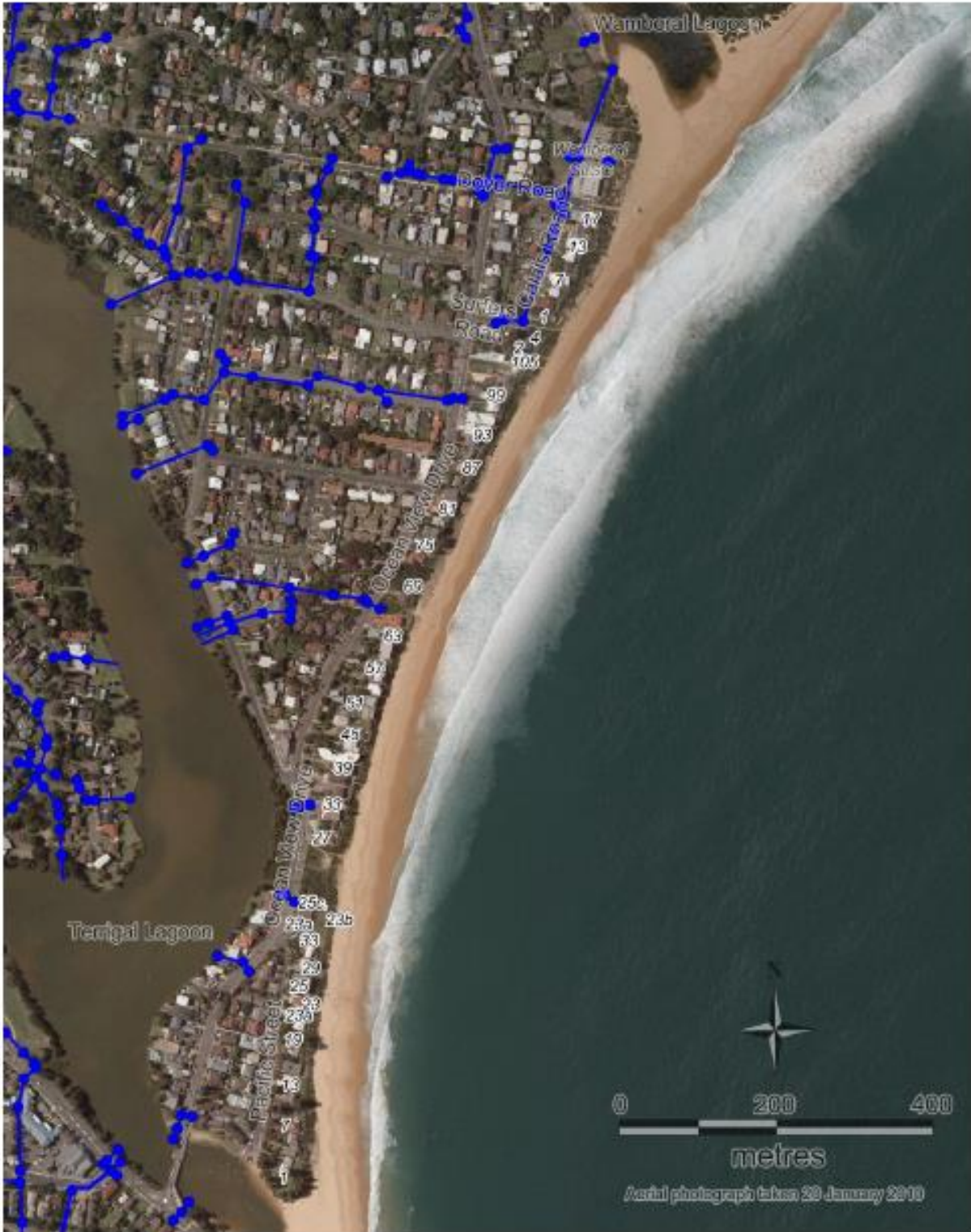


Figure 9.2 Stormwater infrastructure (WP, 2017, Figure 8)



Figure 9.3 Sewer and water infrastructure (WP, 2017, Figure 9)

## 10 OEH (2016) Probabilistic shoreline modelling

Draft Forecast of Potential Shoreline Change Wamberal Beach (Gosford City Council) April 2016.

This draft report was used to inform the cost benefit analysis (Marsden Jacob Associates, 2017). It considered the geomorphology of the embayment, geotechnical conditions and measured long term change. Similar work was published in Kinsela and Hanslow (2013), Kinsela et al (2016), Kinsela et al (2017), Hanslow et al (2017) and OEH (2017) some of which extended to a state-wide assessment.

The modelling incorporated the following components:

- Storm demand
- Underlying sediment budget
- Response to sea level rise

The following variables were quantified or calculated in the modelling, noting that some were set to zero:

- Forecast period
- Length of beach compartment
- Scales for reduced exposure to wave climate or substrate resistance to erosion
- Scales for substrate resistance to ongoing shoreline recession
- Scales for reduced response to sea level rise due to shoreface reefs
- Storm demand volume applied above 0 m AHD
- Cyclic variability associated with beach rotation or periodic headland bypassing
- Annual rate of sand supply from the shoreface or alongshore transport system
- Annual rate of sand loss to the shoreface or alongshore transport system
- Total sea level rise at end of forecast period
- Water depth at profile closure measured from 0 m AHD
- Distance to profile closure depth from dune crest
- Surface area of flood-tide delta deposit (used to calculate sand loss to the lagoon)
- Sand volume lost to tidal inlet/flood-tide delta system throughout compartment
- Annual rate of sand lost to barrier overwash throughout compartment
- Annual rate of sand lost to dunes by aeolian processes throughout compartment
- Annual rate of sand lost offshore due to mega rips throughout compartment
- Annual rate of biogenic sediment production or loss throughout compartment

The probabilities of various shoreline positions in 2034 and 2064 are shown in Figure 10.1 and Figure 10.2.

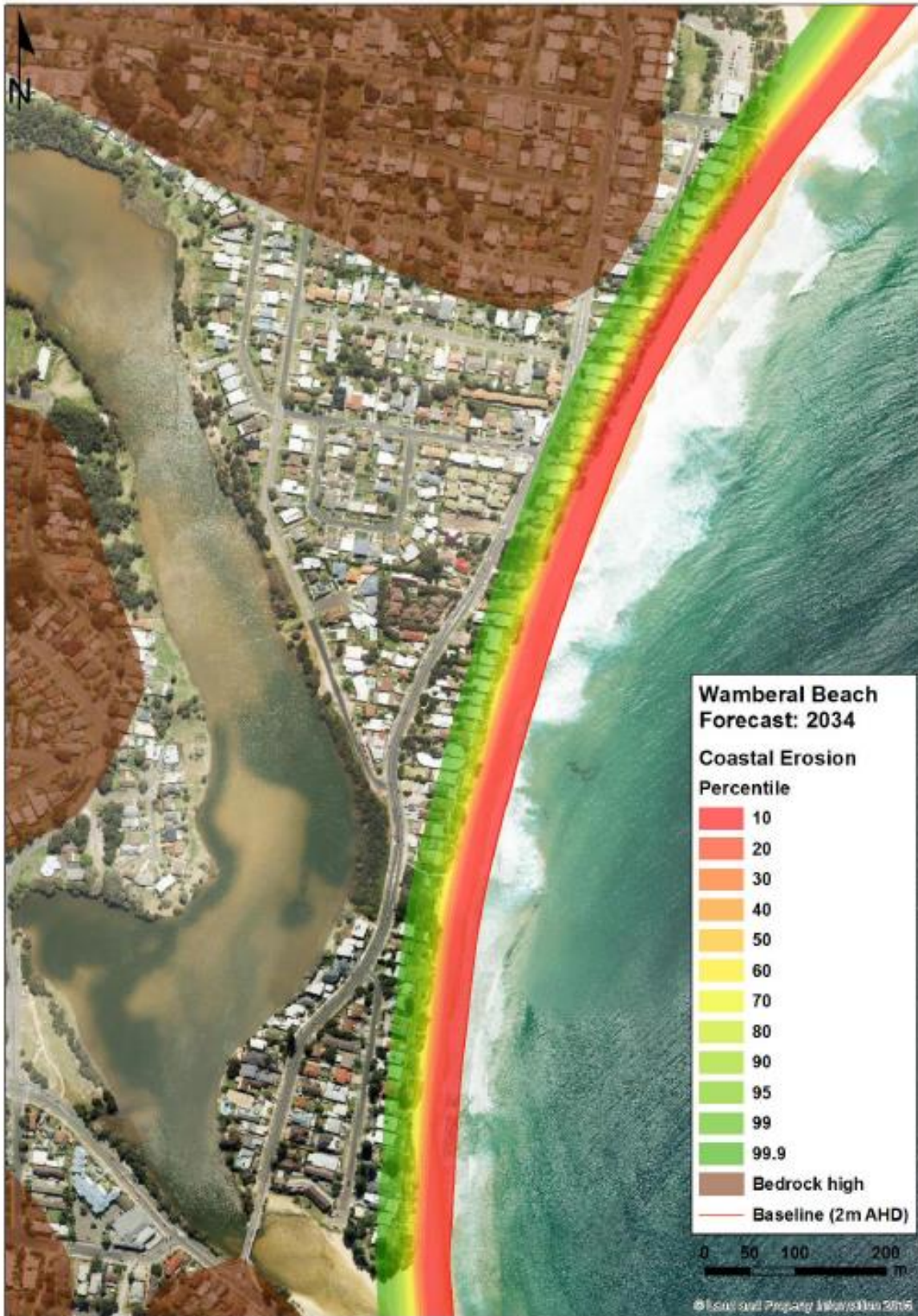


Figure 10.1 Potential shoreline change at 2034 (OEH, 2016, Figure 3)

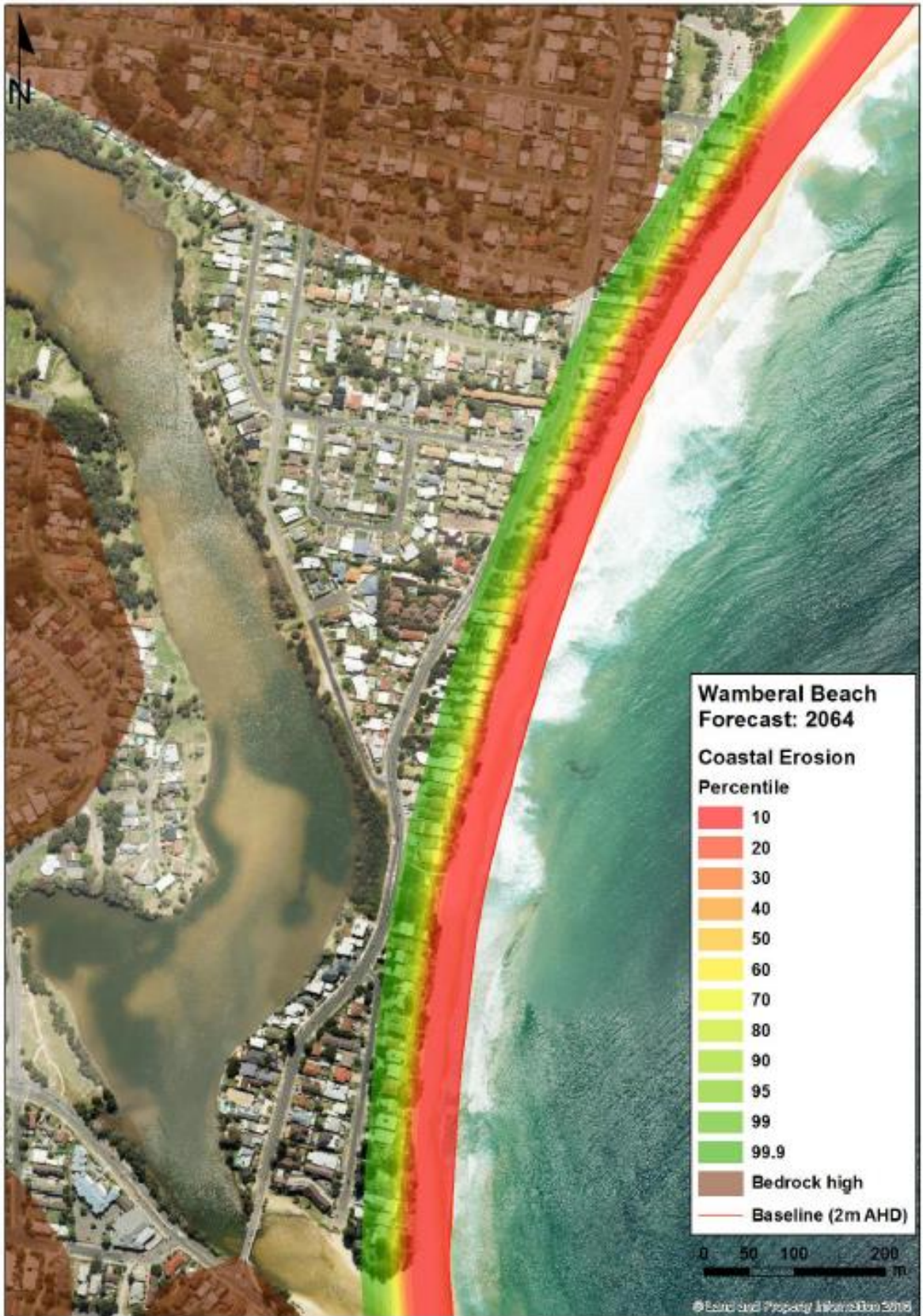


Figure 10.2 Potential shoreline change at 2064 (OEH, 2016, Figure 4)

# 11 Marsden Jacob Associates (2017) Cost Benefit Analysis

Marsden Jacob Associates (2017) Wamberal Beach Management Options: Cost Benefit and Distributional Analysis.

## 11.1 Summary

In this report, a range of engineering approaches were considered to protect beachfront properties and other infrastructure at Wamberal beach. The study used the Cost-Benefit Analysis framework to estimate the direct and indirect costs and benefits of the options that may accrue to a range of critical stakeholders. The analysis concludes that the net costs imposed on residents, visitors and other parties from the loss of the beach and construction of a seawall, exceed the net benefits stakeholders would receive from the effects of a seawall. The critical beneficiaries from the construction of a seawall are the approximately 60 owners of beachfront properties at Wamberal. The analysis considered the following costs and benefits associated with each option: construction cost, maintenance cost, property value, amenity value such as beach users and visitor-related businesses.

## 11.2 Outcomes

The study utilised probabilistic coastal hazard modelling undertaken by OEH (Section 10). It was also reviewed as one of numerous Cost Benefit Analyses in Horton and Rajaratnam (2019).

The following options were examined:

- Option 1: No specific preventative measures
- Option 2: A rubble mound revetment
- Option 3: A rubble mound revetment combined with beach nourishment
- Option 4: A Seabee revetment
- Option 5: A Seabee revetment combined with beach nourishment
- Option 6: A vertical seawall
- Option 7: A vertical seawall combined with beach nourishment
- Option 8: Planned Retreat by managing the duration, type and intensity of future development in the coastal hazard area

The best estimate/default parameter results for BCR and NPV are shown in Table 11.1. Only option 8 – retreat has a BCR > 1 and an NPV > 0.

Note that the NPV for Option 8 is less than the market average market value of one average house (Table 11.1, Table 11.2). Retreat was assumed to be at the owners' loss, with no compensation or buyout.

Page 2 also notes: *“Options where beach nourishment has been considered have a BCR less than 1 and have negative net present values for the community. This is partly due to the costs of beach nourishment outweighing the recreational use benefits of the beach if the beach is maintained in front of a seawall.”*

**Table 11.1 Summary of results of the Cost-Benefit Analysis**

Option	BCR	NPV
Option 1: No specific preventative measures	Base case	Base case
Option 2: A rubble mound revetment	0.70	-\$5.4 m
Option 3: A rubble mound revetment combined with beach nourishment	0.54	-\$11.7 m
Option 4: A Seabee revetment	0.55	-\$9.2 m
Option 5: A Seabee revetment combined with beach nourishment	0.49	-\$14.2 m
Option 6: A vertical seawall	0.49	-\$9.8 m
Option 7: A vertical seawall combined with beach nourishment	0.47	-\$14.0 m
Option 8: Planned Retreat by managing the duration, type and intensity of future development in the coastal hazard area	5.03	\$1.2 m

It is noted that the outcomes and ranking of options in this study are significantly different to those of WorleyParsons (2015), primarily due to different assumptions, particularly with how property losses are treated. Other statistics of interest are shown in Table 11.2.

**Table 11.2 CBA Statistics of interest**

Attribute	Value
Number of properties zoned 'residential' (R2, low density)	84
Number of properties zoned 'commercial' (B1, neighbourhood centre)	9
Number of properties zoned 'other' (RE1, council reserve)	5
Average unimproved value (\$m)	2.0
Average capital improved value (\$m)	2.8
Average coastal land premium value (\$m)	1.1
Average annual rates (\$)	9,340
Average land area (m <sup>2</sup> )	820
Average setback distance of back of house from seaward property boundary (metres)	13



Further notes from the study include:

- The expected value of land and building losses was estimated using the probability of percentage of the land area impacted.
- The travel time cost was considered in the cost section.
- Adopted time frames were 18 and 48 years.

### 11.2.1 Non-resident owners

It appears that losses incurred by 32% of homeowners were not considered (except within the sensitivity tests):

*“As noted above, the trade-off from protecting some sixty beachfront properties with a seawall would be the potential loss of visits due to the loss of the beach. This loss of visitors may create some concern in the wider Central Coast Local Government Area, especially as 32% of the beachfront properties that would potentially be protected by a seawall (at the expense of the beach) are only occupied occasionally (i.e. they are owned by people who use them from time to time as holiday homes, rather than for permanent occupation).”*

### 11.2.2 Nourishment and beach loss

*“The trade-off from protecting beachfront properties with a seawall plus beach replenishment would be to delay when loss of beach visitation will commence however this is offset by the additional cost of beach replenishment.”*

*Page 28: “It is not clear which design will lead to full beach loss the fastest, but it is expected that the beach area will be all but lost by 2064. The loss of the beach will impact negatively on beach users (visitors and the local community), local businesses and property values.”*

### 11.2.3 Comments on loss of land in Marsden Jacob within Planned Retreat

#### **“A4 Impacts on coastal premium land values**

*“Much of the market value of residential or commercial land on Wamberal beach stems from the fact that the land is zoned residential or commercial. If that land is lost due to coastal processes, its ‘zoning value’ is unlikely to be foregone in economic terms because, provided there is not an absolute constraint on land availability within the LGA (and hence property owners are not forced to move away from the LGA), the loss of zoning value to the affected property owners can be expected to be offset by an increase in land values elsewhere within the LGA once additional land is rezoned. This represents a transfer of value of the land from the affected property owners to land developers.*

*On the other hand, a very significant proportion of the market value of properties on Wamberal beach is bound up in their proximity to the beach, i.e. a ‘coastal premium value’. This coastal premium value would be impacted in the event of shoreline erosion, since there are constraints on availability of coastal land within the LGA, i.e. there is no coastal greenfield land on which development could take place in the future. While it is possible that hinterland properties within the vicinity of Wamberal beach and other coastal properties could attract a higher premium in the longer term due to the loss of coastal properties at Wamberal beach, this is unlikely within the timeframe of the analysis.”*

Section A6: All engineering options (options 2 to 7, but not option 8 retreat) have a present value amount for “avoided impacts on buildings and land” of about \$14 million. This can be compared

with a total market value of potentially impacted property (Table 11.2) of \$235 million, noting that future losses are discounted.

The \$221 million differential between these two values could comprise components of: future discounting, piled houses not being lost, only rare and future events impacting some properties, exclusion of the value of the 32% of properties estimated to be owned by non-residents (this was included in the sensitivity tests), and a transfer of value into the *“increase in land values elsewhere within the LGA”*. The proportions or amounts of these components are not readily available within the report.

Draft

## 12 Brief review of selected conference and journal papers

### 12.1 Blumberg and Watson (2007) Basement structures

Blumberg, Gary and Watson, Phil. Wamberal beach basement structures: Provisional model for assessment of additional coastal hazards [online]. In: Coasts and Ports 2007: 18th Australasian Coastal and Ocean Engineering Conference 2007 and the 11th Australasian Port and Harbour Conference 2007. Melbourne: Engineers Australia, 2007: 809-816.

Due to limited land area, site topography, and setback lines from the proposed revetment, substantial basement structures have been proposed and approved for new dwellings at Wamberal. While these new buildings are founded on piled footings, these basement structures may partially act as seawall. Therefore, an assessment technique for their impacts was needed.

Abstract:

*“Gosford City Council (GCC) has developed a proposal for a terminal revetment at Wamberal Beach. In accordance with DCP 125, buildings at Wamberal are permitted seaward of the 2045 Erosion Hazard Line (EHL) but landward of the proposed revetment subject to various conditions, one of which is that the buildings not give rise to any increased hazard. GCC believes that this requirement is achieved with "a suspended structure assuming linear erosion progression of the sand dune". Current proposals for shoreline residences at Wamberal include basement structures (eg carparks) that extend to the seaward side of the design EHL. Council is concerned that these structures may behave differently to suspended structures, potentially giving rise to increased coastal hazard at adjoining properties. Gary Blumberg and Associates (GBA), Coastal, Estuary and River Engineers, have assisted GCC and residential proponents make an assessment of the additional coastal hazards attributed to basements. Various coastal assessment methodologies have been considered and applied, leading to a current approach. This paper summarises the development of ideas and procedures for assessment of the additional coastal hazards, and touches on related planning issues.”*

### 12.2 Lord and Macdonald (2016) Managing Wamberal Beach – The Forgotten Twin

Lord, D., Macdonald, T., 2016. Managing Wamberal Beach – The Forgotten Twin, in: 25th Annual NSW Coastal Conference. Coffs Harbour, 9-11 November 2016.

This study was presented as at the 2016 NSW Coastal Conference and describes post June 2016 storm erosion responses and management of ongoing risks at Wamberal Beach. The study includes findings from preliminary post-storm risk assessments and post-storm responses that included removal of foreign ad-hoc material present on the beach, slope stabilisation options and preliminary assessment of dwelling stability. Post-storm remedial actions by Council and homeowners are discussed. Ongoing management issues for Wamberal Beach identified in the study included the adverse impacts of ad-hoc protection works placed on the beach in response to the storm and increased reliance on temporary emergency response works, both highlighting the need to progress a holistic long-term management strategy from the Gosford Beaches CZMP (in draft at the time) as a priority.

## 12.3 Horton and Rajaratnam (2019) Cost Benefit Analysis in Coastal Management – Getting it Right and Getting it Wrong

Horton, P., Rajaratnam, N., 2019. Cost benefit analysis in coastal management-getting it right and getting it wrong, in: Australasian Coasts and Ports 2019 Conference: Future Directions from 40°S and beyond, Hobart, 10-13 September 2019. Engineers Australia, p. 603.

This study looks at the factors considered to be key to the successful implementation of a cost-benefit analysis (CBA) in supporting coastal management outcomes. These factors are noted to include

- correctly defined and applied probabilistic coastal hazard lines to determine annual coastal erosion hazard probabilities for each year over a planning period.
- close collaboration between the coastal engineer and economist including the review of each other's work and assumptions.
- testing of assumptions including careful assessment and sensitivity testing to ensure assumptions are reliable and defensible.
- framing the CBA to avoid undertaking the analysis with bias or hopes of a certain outcome and lacking scrutiny of assumptions driving results.
- not overrating the importance of CBA recognising that the answer provided by the CBA is not the only answer but rather is one of many considerations making decisions on a complex and often multifaceted matter.
- not overdoing CBA with reference to the requirement of CBA for projects of different scale and complexity.

As part of the study, outcomes of the Wamberal Beach CBA by Marsden Jacobs Associates (2017) were evaluated with discussion of certain assumptions adopted in the study including:

- Loss of beach amenity for the status quo (base case scenario) was considered substantially less than for a seawall located at the back of the beach on private land.
- Loss of beach width due to long term recession was not assessed in a probabilistic manner and potentially over estimated.
- Impacts on beach width of vertical and rock revetments were assumed to be the same and did not consider alignment or footprint implications.
- Planned retreat was assumed to be implemented by forcing demountable and relocatable houses to be built when non-piled dwellings were redeveloped and did not consider existing use rights for owners.
- Planned retreat did not have any associated costs other than relocating dwellings, assuming a transfer of property value elsewhere in the LGA with no property owner compensation.

## 13 Review of additional economic studies

### 13.1 Preamble

As part of the present study a critical literature review has been undertaken of the coastal ecosystem services that coastal areas provide, an assessment of the economic values placed on these services, and a critical review of the methods and approaches used to value coastal services. This review serves to provide an understanding of different values that beaches and coastal areas provide to local residents, businesses and government, as well as the general community, relevant to the Wamberal Beach.

In addition to the studies described earlier, this section provides a summary of additional primary economic studies and papers that have been reviewed and will be used alongside ongoing research to estimate market and non-market, use and non-use values of Wamberal Beach as part of the Stage 6 Cost Benefit Analysis (CBA). In addition to the articles described in this section, the authors have reviewed numerous other articles and studies to ensure that the Stage 6 economic analysis takes advantage of the most up-to-date and appropriate values. Further economic studies and resources are listed in Sections 13.7 and 13.8.

### 13.2 Fei Yang (2014). Employ Cost-Benefit Analysis to Evaluate the Cost Efficiency of Major Sea Level Rise Adaptation Strategies

This report provides a comprehensive study of sea-level rise and adaptation planning. This study considers the gaps between available literature applying the cost-benefit measure to analyse sea level rise, or its adaptation strategies do not take full consideration of the indirect economic impact of various adaptation strategies. The research aims to bridge these gaps by integrating both direct and indirect economic effects of sea-level rise into a cost-benefit analysis framework, which is applied to evaluate most commonly adopted adaptation strategies. The author categorised adaptation strategies in to two main categories named hard and soft. Hard adaptation included protection, retreat and accommodation. Soft category included planning, regulation and incentives.

*Further notes:* good source in identifying different values associated with sea wall and other adaptation strategies.

### 13.3 Balmoral Group Australia (2014). Cost-Benefit Analysis of Options to Protect Old Bar from Coastal Erosion.

The report considered social, economic, and environmental implications of the eight options under consideration. At the outset, there are no clear “winners” because of the severe recession scenario. All of the alternatives represent a loss to some party – loss of the more significant part of the beach, in some scenarios; loss of private property in others; loss of sensitive habitat; or lifestyle for others. The cost-benefit analysis found that the most cost-effective option is a Planned Retreat with Purchased Easements, which provides limited compensation for beachfront property owners in return for their agreement to vacate when trigger events occur. The analysis considered three types of costs to the community: direct, indirect and non-market as characterised as follows.

1. Direct costs – cash, council staff time or other direct expenditure, as for construction or maintenance,

2. Indirect costs – generally, a loss of income due to loss of some activity, etc.
3. Non-market costs – generally, the value of something that the public values.

Likewise, the analysis considered three types of benefits: community-oriented, recreational, and environmental including:

1. Community benefits – broad, commerce-based benefits that accrue to the community in general,
2. Recreational and amenity benefits – surfing and beach visitors, and
3. Environmental benefits – published values for various ecological assets.

*Further notes:* Willingness to pay and benefit transfer methods have been used. Time frames: 20 and 60 years. Hedonic modelling used to estimate the loss value of properties under different scenarios of erosion.

### 13.4 Balmoral Group Australia (2015). Cost-Benefit Analysis of Coastal Management Options for Lake Cathie.

This report aimed to complete a comprehensive cost-benefit analysis of previously identified management options to manage future coastal hazards operating at Lake Cathie. The body of the report describes how each of the options has been treated in the analysis. The analysis quantified the expected costs and benefits to various stakeholders in the community, from a number of options in addition to those initially detailed in Council's draft CZMP. The CBA also included a socio-economic profile of the township of Lake Cathie. The analysis considered three types of costs to the community; direct, indirect and non-market, including:

1. Direct costs – cash, council staff time or other direct expenditure, as for construction or maintenance
2. Indirect costs – generally, a loss of income or asset value due to loss of some activity, etc., and
3. Non-market costs - generally, the value of something that the public values and will no longer have.

Likewise, the analysis considered three types of benefits; community-oriented, recreational, and environmental. The latter categories may include direct expenditures and proxies for value identified by "willingness-to-pay (WTP)."

1. Community benefits are broad, commerce-based benefits that accrue to the community in general, not to a specific party, in addition to the value of a protected property,
2. Recreational benefits such as surfing by residents and visitors, and
3. Environmental benefits are published willingness-to-pay values for various ecological assets

*Further notes:* Nine management options are considered. Hedonic modelling is used to estimate the impact of erosion on property values. Time frames: 20 and 50 years. Probabilistic Risk Profiles provided by OEH.

### 13.5 Sean Pascoe and Amar Doshi (2018). Estimating coastal values using multi-criteria and valuation methods, CSIRO.

The main aim of the study was to derive estimates of the non-market value of critical coastal assets that could potentially aid in decision making in coastal councils. Non-market values represent the value of the asset to the local community, based on how much they would be willing to pay for them if they were required to pay. While the primary aim of the study was to estimate non-market values of the coastal environmental assets themselves, the study also evaluated the value of recreational use for the beach as a whole as it became apparent during the survey that recreational use values were also likely to be significant in driving resource management decisions.

Finally, the study had a research methodology objective; namely to test the utility in combining traditional non-market economic valuation technique (which is limited in how many assets could potentially be incorporated reliably) with multi-criteria decision analysis approaches to priority setting. The advantage of the latter is that relative preferences can be estimated for a broader set of assets, even though monetary values are not directly derived.

*Further notes:* two primary methods that have been used are the Analytic Hierarchy Process (AHP) and the Choice Experiment. Recreational use values were estimated using a travel cost model. A survey of 1414 NSW coastal residents was undertaken to elicit the preferences and values. A substantial difference was observed in the general preference for beach type between Sydney and non-Sydney residents. As a result of this observation, the analysis of preference was undertaken separately for Sydney and non-Sydney residents.

### 13.6 City of Newcastle (2020). Cost-benefit analysis for Stockton Beach coastal management program.

In this report, a cost-benefit analysis was undertaken in support of the coastal management program being prepared by the City of Newcastle for the area north of the Stockton Breakwater. Three coastal management options have been assessed in the CBA. The CBA has quantified the crucial benefits and costs for the specified community in monetary terms.

Environmental values included dune system and vegetation seaward, dune systems along the coast north, an urbanised area along the central section of the beach with exotic grasses and planted landscape species. Economic values used in the study included land values, Council assets, buildings, revenue/spending.

The critical benefits incorporated within this analysis were in the form of Maintained beach area and associated non-use and use-values, and Reduced loss of property and land to both private landowners and the Council. The estimated benefits are as follow: beach amenity (use and non-use values but tourism values not included), avoided private property loss, avoided public land loss, avoided public infrastructure loss, avoided loss of producer surplus, and residual value.

*Further notes:* Benefit transfer approach was applied to estimate non-market costs and benefits. The average land value per block is used to estimate property loss value within each of the 16 probability of exceedance scenario. Time frames: 2020, 2040, 2060, 2120.

## 13.7 Further resources

- Barbier, E.B., Hacker, S.D., Kennedy, C., Koch, E.W., Stier, A.C. and Silliman, B.R., 2011. The value of estuarine and coastal ecosystem services. *Ecological monographs*, 81(2), pp.169-193.
- Blackwell, B., 2007. The value of a recreational beach visit: An application to Mooloolaba beach and comparisons with other outdoor recreation sites. *Economic Analysis and Policy*, 37(1), pp.77-98.
- Clouston, E., 2003. Linking the ecological and economic values of wetlands: a case study of the wetlands of Moreton Bay. Griffith University.
- Kinsela, M.A., Morris, B.D., Linklater, M. and Hanslow, D.J., 2017. Second-pass assessment of potential exposure to shoreline change in New South Wales, Australia, using a sediment compartments framework. *Journal of Marine Science and Engineering*, 5(4), p.61.
- Lew, D.K. and Larson, D.M., 2005. Valuing recreation and amenities at San Diego County beaches. *Coastal management*, 33(1), pp.71-86.
- Lockwood, M. and Carberry, D., 1999. Stated preference surveys of remnant native vegetation conservation (No. 410-2016-25570).
- Lord D, Macdonald T., 2019. Managing Wamberal Beach – The Forgotten Twin. Coastal Conference Terrigal.
- Sally Kirkpatrick, 2011. The Economic Value of Natural and Built Coastal Assets. National Climate Change Adaptation Research Facility (NCCARF).
- Sangha, K.K., Stoeckl, N., Crossman, N. and Costanza, R., 2019. A state-wide economic assessment of coastal and marine ecosystem services to inform sustainable development policies in the Northern Territory, Australia. *Marine Policy*, 107, p.103595.
- Van Bueren, M. and Bennett, J., 2004. Towards the development of a transferable set of value estimates for environmental attributes. *Australian Journal of Agricultural and Resource Economics*, 48(1), pp.1-32.
- Zhang, F., Wang, X.H., Nunes, P.A. and Ma, C., 2015. The recreational value of gold coast beaches, Australia: An application of the travel cost method. *Ecosystem Services*, 11, pp.106-114.

## 13.8 Media and websites

- Wamberal Beach erosion reports released, POSTED BY: CENTRAL COAST NEWSPAPERS JUNE 21, 2018. Available at: <http://www.centralcoastnews.net/2018/06/21/wamberal-beach-erosion-reports-released/>
- Wamberal Beach erosion: Funding for seawall design and beach nourishment Fiona Killman, Central Coast Gosford Express Advocate October 19, 2018. Available at: <https://www.dailytelegraph.com.au/newslocal/central-coast/wamberal-beach-erosion-funding-for-seawall-design-and-beach-nourishment/news-story/61a61eea5a5706dd571e7f1cb2a0c39d>



Major erosion threatens \$400m worth of Wamberal homes, infrastructure Matt Taylor and Denice Barnes, Central Coast Gosford Express Advocate June 8, 2016. Available at: <https://www.dailytelegraph.com.au/newslocal/central-coast/major-erosion-threatens-400m-worth-of-wamberal-homes-infrastructure/news-story/9897149515c200b5f8d2fc1e4a7f38f1>

Funding for design of a Wamberal Beach solution, OCTOBER 28, 2018. Available at: <https://coastcommunitynews.com.au/central-coast/news/2018/10/funding-for-design-of-a-wamberal-beach-solution/>

Government report predicts a grim future for Wamberal Beach, JULY 6, 2018. Available at: <https://coastcommunitynews.com.au/central-coast/news/2018/07/government-report-predicts-a-grim-future-for-wamberal-beach/>

Urgent Report on Terrigal, Wamberal Beaches To Be Developed, 24 April 2018. Available at: <https://www.triplem.com.au/story/urgent-report-on-terrigal-wamberal-beaches-to-be-developed-91122>

Wamberal-Terrigal beach NSW, available at: <https://beachsafe.org.au/beach/nsw/gosford/terrigal/terrigal>

Draft

## 14 Conclusions

Wamberal Beach is within the traditional boundaries of Darkinjung (Darkinyung) land. Wamberal Beach has had a long history of beachfront development and coastal erosion. This document provides a summary and review of literature relevant to coastal management and a proposed seawall for Wamberal.

Extreme erosion during storms in 1974 (including the Sygna storm) resulted in emergency dumping of rock and sandbags by the Australian Army and the NSW SES. Two houses were lost due to storm erosion in 1978, with one of these lost houses resulting in the Egger legal case. Mrs Egger sued Gosford Shire Council and Mrs Brendel (the developer of 'Manyana' building) "for damages for negligence but ultimately the suit did not proceed against Mrs Brendel, as ... these parties had resolved the matter between themselves." The judgement stated that the apartment development known as Manyana was initially refused by Council in 1968 due to coastal hazards. A revised application set further back and founded on piles was approved. An ad hoc seawall fronting this development caused end effect erosion to its north. All four coastal expert witnesses agreed that a rip had formed in front of the Egger property, contributing to the erosion which led to its collapse. Smart, J, found that the seawall fronting Manyana contributed to the formation of this rip, but his judgment was "on the balance of probabilities. ... [the] balance was a fine one". He also found that no Council engineer or Council in 1968 would have been expected to have knowledge of such processes, so no adverse findings were made against Council. These findings were largely confirmed in an appeal hearing where the judgement of Smart was reviewed. It examined foreseeability, duty of care, liability, proximity and negligence. The Court of Appeal concurred that Council was not negligent. Mrs Egger was ordered to pay one half of the costs of the original hearing and the full costs of the appeal. That is, Council was ordered to pay half the costs of the original case because it (Council) lost on one issue - the issue of causation.

Following the erosion events of the 1970's a number of studies were undertaken investigating coastal processes, hazards and management of Wamberal Beach. The PWD (1985) study covered Avoca and Wamberal beaches and was the first modern coastal engineering study for this area. The PWD (1994) study estimated long term recession at Wamberal of 0.3 m/year and design storm erosion of 250 m<sup>3</sup>/m. Sand was believed to be lost to offshore reefs and canyons, and into the lagoons. The 1995 Coastal Management Study (CMS) and Coastal Zone Management Plan (CZMP, 1995) recommended either ongoing large-scale sand nourishment or a terminal protection in the form of a seawall.

In the late 1990's, a range of seawall options were canvassed by WRL (1998), with Council and its committee selecting a Seabee seawall with a wave return crest. The design of this was further developed and detailed by WRL. It was a whole of embayment design (lagoon to lagoon) and included detailed consideration of the alignment and physical modelling to refine crest elevations of 6 to 8 m AHD along the structure. The Seabee design was estimated to cost: \$7.2 million for 1360 m, \$5,300/m and \$90,000 per 17 m property frontage. In 2004, 120 m of the seawall design at the northern end was realigned due to development at 17 Calais Rd, Wamberal (MHL, 2004). As part of the study costs to construct the seawall were revised from \$7.2 million to \$8.2 million.

An Environmental Impact Statement (EIS) for this seawall was prepared by MHL (2003). The seawall was considered with accompanying periodic small-scale (estimated at 20,000 m<sup>3</sup>/year) beach nourishment to maintain beach amenity. The only potentially viable alternative was found to be large-scale sand nourishment (initial 900,000 m<sup>3</sup> and ongoing 200,000 m<sup>3</sup> every 10 years), but

this was restricted by the lack of an accessible sand source.

Securing financial support has been an ongoing stumbling block for the construction of the seawall design. The Gosford Beaches Coastal Zone Management Plan (CZMP, 2017) reported: “On the 30 March 2006, the Mayor, the General Manager and Council's Principal Environmentalist met with the Minister Kelly along with his Policy Adviser on Emergency Services. At the meeting Council presented a detailed briefing paper. In summary, the briefing paper requested funding assistance of a one-off request of \$2.8 million from the State Government towards the construction of an \$8.2 million terminal protection structure (seawall) along Wamberal Beach. Council sought a similar financial assistance from the Federal Government of \$2.8 million and intended to seek the balance of \$2.8 million from the 78 residential properties that front Wamberal Beach to cover the total project cost of \$8.2 million. Council has since endeavoured to source grant funds through the State's Coastal Management Program and the Federal Government's Natural Disaster Mitigation Program. Council has also lobbied State and Federal governments, however, all efforts to secure financial assistance for the project have been unsuccessful.”

More recently in the last 10 years, coastal hazard and management studies have been undertaken for Wamberal Beach. The Coastal Hazard Definition Study (CHDS, 2014) found the following for Wamberal Beach:

- Underlying recession of 0.2 m/year
- A Bruun Factor of about 43, that is, recession due to sea level rise (SLR) would be 43 times the SLR
- “Design” (nominally 100-year Annual Recurrence Interval ‘ARI’) storm erosion of 250 m<sup>3</sup>/m
- 68 dwellings potentially impacted by coastal hazards by 2050

The Gosford Beaches Coastal Management Study (2015) and Coastal Zone Management Plan (CZMP, 2017) concluded that the only viable options for Wamberal were terminal protection in the form of a seawall and sand nourishment to increase storm buffer, with large scale sand nourishment constrained by the absence of an accessible sand source.

Earlier coastal hazard studies were undertaken to best practice of the time, and adopted “design”, “conservative”, “precautionary”, 100-year ARI/1% Annual Exceedance Probability (AEP) parameters. While these inputs remain relevant for planning purposes and engineering assessments, they may overstate the economic losses associated with coastal hazards. Therefore, OEH (2016) undertook probabilistic coastal hazard assessment for the years 2034 and 2064 to best contemporary practice, to provide quantitative input for a cost benefit analysis.

The Cost Benefit Analysis (Marsden Jacob Associates, 2017) assessed eight coastal management options relative to the status quo. It found that that 84 private properties with an average improved value of \$2.8 million and total value of \$235 million were potentially vulnerable to coastal hazards. Only Planned Retreat had a positive Net Present Value (NPV) and a Benefit Cost Ratio (BCR) above 1, but the NPV for this (\$1.2 million) was still less than the value of a single house. Retreat was considered to be at the owners’ loss. For all protection options, the “avoided impacts on buildings and land” were about \$14 million. This can be compared with a total market value of potentially impacted property of \$235 million, noting that future losses are discounted. The \$221 million differential between these two values could comprise components of: future discounting, piled houses not being lost, only rare and future events impacting some properties, exclusion of the value of the 32% of properties estimated to be owned by non-residents (this was included in the sensitivity tests), and a transfer of value into the “increase in land values elsewhere within the LGA”.

Additional key economic studies have been reviewed and highlight the need for an updated cost benefit and distributional analysis of coastal management options for Wamberal Beach that is developed in close collaboration with coastal engineers and utilises up-to-date information and assumptions that are tested to best capture the losses and benefits of all interested parties. This is to be undertaken recognising that results of such analysis are only one tool used in the decision-making process for selecting a preferred option (i.e. it alone won't tell you what the answer should be) and are to be considered alongside broader inputs such as coastal engineering and management studies, stakeholder consultation, and legislative requirements.

It has now been 46 years since the Australian Army and SES undertook emergency rock and sandbag protection for most of the houses at Wamberal, and 35 years since the first PWD study of the coastal hazards prevailing there. Underlying recession has continued at 0.2 m/year since then, together with SLR of 1 to 3 mm/year. Thus, the need for active coastal management is now greater than it was during the earlier storm events and studies. All previous coastal management studies have recommended terminal protection in the form of a seawall and sand nourishment as the most viable options for providing protection and maintaining foreshore amenity of Wamberal Beach. Large scale sand nourishment is constrained by the absence of an accessible sand source, this absence being legislative and planning rather than physical, and may result in further implications on flooding and entrance management.

Furthermore it is now over 20 years since the previous seawall designs were developed for Wamberal Beach, with the Gosford Beaches CZMP (2017) highlighting the need for an updated review of the previous design and updated investigation into potential sand sources for beach nourishment. Since the former seawall design new information and datasets have become available to inform the development of seawall design options, and the area has seen substantial changes in beachfront home ownership, property values and community values. Long-term shoreline datasets from satellite imagery and photogrammetry have now become available and combined with new methodologies provide an opportunity to undertake a more detailed assessment of the potential impacts of seawall designs on beach width and amenity.

In July 2020 during the undertaking of this review, Wamberal Beach experienced substantial coastal erosion resulting in damages to beach front properties and more than 4000 tonnes of temporary emergency rock protection being placed on the beach. This recent event provides key learnings of the costs and impacts associated with the present status quo of emergency response and reactive ad-hoc protection works during major coastal erosion events, highlighting the importance of implementing a more sustainable long-term coastal management strategy. The event has also led to heightened community interest in coastal management options for Wamberal Beach with opportunity to re-engage with and understand stakeholder values.

An updated study of concept design options for terminal protection at Wamberal Beach is warranted, incorporating the following:

- Development and costings of seawall concept design options for Wamberal Beach using up to date information, methodologies and standards including sea level rise implications.
- Impact assessment of seawall design options on beach width and amenity using up to date information and methodologies.
- Updated sand nourishment investigation including sources, requirements and costings.
- Updated cost-benefit and distributional analysis of different seawall concept design options alongside other options including planned retreat and the present status quo (informed by recent events including impacts and emergency response costings).
- Community engagement to inform a preferred option and considerations for detailed design

## References

- AWACS (1994) The entrance dynamics of Wamberal, Terrigal, Avoca and Cockrone Lagoons
- Baird Australia, MHL, (2017). NSW Coastal Wave Model - Statewide Nearshore Wave Transformation Tool. NSW Office of Environment and Heritage, Sydney, Australia.
- Blumberg, Gary and Watson, Phil. Wamberal beach basement structures: Provisional model for assessment of additional coastal hazards [online]. In: Coasts and Ports (2007): 18th Australasian Coastal and Ocean Engineering Conference 2007 and the 11th Australasian Port and Harbour Conference 2007. Melbourne: Engineers Australia, 2007: 809-816.
- BMT WBM (2012) Coastal Zone Management Study for Gosford Lagoons R.N1997.001.01\_Draft October 2012 (135 pages)
- Gosford City Council (1995) Coastal Management Study and Coastal Management Plan Gosford City Open Beaches, WBM Oceanics Australia, Planning Workshop
- Gosford City Council (1996) DCP No 89 (1996)
- Hanslow, D.J., Dela-Cruz, J., Morris, B.D., Kinsela, M.A., Foulsham, E., Linklater, M. and Pritchard, T.R., 2016. Regional scale coastal mapping to underpin strategic land use planning in southeast Australia. *Journal of Coastal Research*, (75), pp.987-991.
- Hope (1), Samuels And Clarke (2) JJA Supreme Court Of New South Wales Court Of Appeal, Hope (1), Samuels And Clarke (2) JJA, 588 Of 1987, 22, 23, 24, 27 June 1988, 10 March 1989
- Horton Coastal Engineering (19 September 2016) Coastal Engineering Report and Statement of Environmental Effects for Construction of Rock Revetment at 29, 31 and 33 Pacific Street and 23a, 23b and 25c Ocean View Drive Wamberal
- Horton, P., Rajaratnam, N., 2019. Cost benefit analysis in coastal management-getting it right and getting it wrong, in: Australasian Coasts and Ports 2019 Conference: Future Directions from 40°S and beyond, Hobart, 10-13 September 2019. Engineers Australia, p. 603.
- Hudson, J P (1997) Gosford City Council Open Ocean Beaches Geotechnical Investigations (Avoca Beach, Wamberal Beach, Forresters Beach
- Kinsela, M.A., Morris, B.D., Daley, M.J. and Hanslow, D.J., 2016. A flexible approach to forecasting coastline change on wave-dominated beaches. *Journal of Coastal Research*, (75), pp.952-956.
- Kinsela, M.A., Morris, B.D., Linklater, M. and Hanslow, D.J., (2017). Second-pass assessment of potential exposure to shoreline change in New South Wales, Australia, using a sediment compartments framework. *Journal of Marine Science and Engineering*, 5(4), p.61.
- Lord, D., Macdonald, T., 2016. Managing Wamberal Beach – The Forgotten Twin, in: 25th Annual NSW Coastal Conference. Coffs Harbour, 9-11 November 2016.
- Marsden Jacob Associates (2017) Wamberal Beach Management Options: Cost Benefit and Distributional Analysis
- MHL (1998) Terrigal Lagoon dredging. MHL902, NSW Office of Finance and Services, Manly Hydraulics Laboratory, Sydney, Australia.

- MHL (2003) Wamberal Beach and property protection: Environmental Impact Statement (2003), MHL Report MHL935, DPWS Report 98047, ISBN 0 7313 0716 X
- MHL (2004). Coastal Engineering Advice Realignment and Cost Review of Wamberal Terminal Portection Structure and Beach Nourishment. NSW Department of Commerce, Manly Hydraulics Laboratory, Sydney, Australia.
- OEH (2016) Draft Forecast of Potential Shoreline Change Wamberal Beach (Gosford City Council) April 2016.
- PWD (1984) Seabed maps, Gosford
- PWD (1985) Gosford Coastal Processes Investigation
- PWD (1994) Gosford Coastal Process Investigation
- Smart J, (1987) Egger Case in the Supreme Court of New South Wales Common Law Division No 14992 of 1979, Egger v Gosford Shire Council and Anor – Judgement 10 July 1987
- Webb McKeown (1995) Wamberal Lagoon Estuary Processes
- WorleyParsons (2014) – Appendix H Analysis of photogrammetric data – Terrigal-Wamberal
- WorleyParsons (2014) Gosford City Council open coast and Broken Bay beaches Coastal processes and hazard definition study
- WorleyParsons (2015) Open Coast and Broken Bay Beaches Coastal Zone Management Study 301015-03417 – CS-REP-0001 16 Apr 2015
- WorleyParsons (2017) Gosford Beaches Coastal Zone Management Plan 301015-03417 – 003 3 April 2017
- WRL (1997) Wamberal Beach Terminal Protection Structure – Physical Modelling Study, WRL Technical Report 97/26
- WRL (1998a) Design study for Wamberal Beach: terminal protective structure
- WRL (1998b) Wamberal Beach Terminal Protection Structure – Final Design Drawings and Technical Specification, WRL Technical Report 98/05